

OPERATING MANUAL

SDPROC COMMAND MODULES



Aalborg® is a registered trademark of Aalborg Instruments & Controls.

NOTE: Aalborg reserves the right to change designs and dimensions at its sole discretion at any time without notice. For certified dimensions please contact Aalborg®.

TABLE OF CONTENTS

(a)	UNPACKING THE SDPROC COMMAND MODULE	1
a.1	Inspect Package for External Damage.....	1
a.2	Unpack the Command Module.....	1
a.3	Returning Merchandise for Repair.....	1
(b)	INSTALLATION	1
b.1	Location of Installation.....	1
b.2	Electrical Connections.....	2
b.2.1	Connecting Flow Transducers.....	2
b.2.2	Power Input.....	3
b.2.3	Applying Power to the SDPROC.....	3
b.2.4	Remote Signal Interface.....	3
b.2.5	Relays Interface.....	4
(c)	DESCRIPTION	4
(d)	SPECIFICATIONS	4
d.1	CE Compliance.....	5
(e)	OPERATING INSTRUCTIONS	6
e.1	Preparation and Warm Up.....	6
e.2	Single Channel SDPROC.....	6
e.2.1	Start up Display.....	6
e.2.2	Main Display.....	6
e.2.3	Control Mode Status.....	7
e.2.4	Set Point Display.....	7
e.2.5	Totalizer / Alarm Display.....	8
e.2.6	Setup Channel Display.....	8
e.2.6.1	Internal/External/Program Reference.....	9
e.2.6.2	Setup Gas Density Display.....	9
e.2.6.3	Setup Engineering Units Display.....	10
e.2.6.4	Setup Full Scale Flow Rate Display.....	10
e.2.6.5	Setup Relays Assignment Display.....	10
e.2.7	Setup Alarm Display.....	11
e.2.7.1	Setup Alarm Mode Display.....	11
e.2.7.2	Setup Alarm Low Display.....	11
e.2.7.3	Setup Alarm High Display.....	11
e.2.7.4	Setup Alarm Delay Display.....	12
e.2.7.5	Setup Alarm Action Display.....	12
e.2.8	Setup Totalizer Display.....	12
e.2.8.1	Setup Totalizer Mode Display.....	13
e.2.8.2	Setup Totalizer Start Flow Display.....	13
e.2.8.3	Setup Totalizer Stop Volume Display.....	13
e.2.8.4	Setup Totalizer Action Display.....	13

e.2.9	Program Settings Display.....	14
e.2.9.1	Batch Program Settings Display.....	14
e.2.9.2	Timer Program Settings Display.....	16
e.2.10	Status Check.....	17
e.3	Multi Channel SDPROC.....	17
e.3.1	Start up Display.....	17
e.3.2	Main Display.....	18
e.3.3	Channel Select.....	18
e.3.4	Set Point Display.....	19
e.3.5	Control Mode Display.....	19
e.3.6	Totalizer/Alarm Status Display.....	19
e.3.7	Setup Channel Display.....	20
e.3.7.1	Internal/External/Program Reference.....	20
e.3.7.2	Setup Gas Density Display.....	21
e.3.7.3	Setup Engineering Units Display.....	21
e.3.7.4	Setup Full Scale Flow Rate Display.....	21
e.3.7.5	Setup Relays Assignment Display.....	22
e.3.8	Setup Alarm Display.....	22
e.3.8.1	Setup Alarm Mode Display.....	22
e.3.8.2	Setup Alarm Low Display.....	23
e.3.8.3	Setup Alarm High Display.....	23
e.3.8.4	Setup Alarm Delay Display.....	23
e.3.8.5	Setup Alarm Action Display.....	23
e.3.9	Setup Totalizer Display.....	24
e.3.9.1	Setup Totalizer Mode Display.....	24
e.3.9.2	Setup Totalizer Start Flow Display.....	24
e.3.9.3	Setup Totalizer Stop Volume Display.....	25
e.3.9.4	Setup Totalizer Action Display.....	25
e.3.10	Program Settings Display.....	25
e.3.10.1	Batch Program Settings Display.....	26
e.3.10.2	Timer Program Settings Display.....	27
e.3.10.3	Ratio Program Settings Display.....	28
e.3.11	All Valves Control.....	30
e.3.12	Real Time Clock Settings.....	31
e.3.13	Status Check.....	31
(f)	MAINTENANCE.....	32
(g)	ADC/DAC CALIBRATION PROCEDURES.....	32
g.1	Digital to Analog (D/A) Slope Calibration.....	33
g.2	Analog to Digital (A/D) Calibration.....	34
(h)	RS-232 SOFTWARE INTERFACE COMMANDS.....	35
h.1	General.....	35
h.2	Commands Structure.....	35
h.3	ASCII Commands.....	37

(i)	NETWORK COMMUNICATION INTERFACE (OPTIONAL)	42
i.1	0Base-T RJ-45 Pinout.....	42
i.2	Network Protocols.....	42
i.2.1	DHCP.....	42
i.2.2	DNS.....	43
i.2.3	IP Address.....	43
i.3	Configuration.....	43
i.4	Operation Using the SDPROC Web Page.....	44
i.5	Operation Using the SDPROC Telnet Console.....	45
(j)	TROUBLESHOOTING	46
j.1	Common Conditions.....	46
j.2	Troubleshooting Guide.....	47
j.3	Technical Assistance.....	47
APPENDIX 1	COMPONENT DIAGRAM	48
APPENDIX 2	DIMENSIONAL DRAWINGS	49
APPENDIX 3	WARRANTY	50

(a) UNPACKING THE SDPROC COMMAND MODULE

a.1 Inspect Package for External Damage

Your SDPROC Command Module was carefully packed in a sturdy cardboard carton, with anti static cushioning materials to withstand shipping shock. Upon receipt, inspect the package for possible external damage. In case of external damage to the package contact the shipping company immediately.

a.2 Unpack the Command Module

Open the carton carefully from the top and inspect for any sign of concealed shipping damage. In addition to contacting the shipping carrier please forward a copy of any damage report to your distributor or Aalborg® directly.

When unpacking the instrument please make sure that you have all the items indicated on the Packing List. Please report any shortages promptly.

a.3 Returning Merchandise for Repair

Please contact the customer service representative of your distributor or Aalborg® if you purchased the equipment directly, and request a Return Authorization Number (RAN). Equipment returned without an RAN will not be accepted. Aalborg® reserves the right to charge a fee to the customer for equipment returned under warranty claims if the instruments are tested to be free from warranted defects.

Shipping charges are borne by the customer. Equipment returned “collect” will not be accepted!

It is mandatory that any equipment returned for servicing be purged and neutralized of any dangerous contents including but not limited to toxic, bacterially contagious, corrosive or radioactive substances. No work shall be performed on a returned product unless the customer submits a fully executed, signed SAFETY CERTIFICATE. Please request form from the Service Manager.

(b) INSTALLATION

See AFM/AFC/GFM/GFC/DFC manual for specific instructions on the use and operation of the mass flow meter or mass flow controller transducers.

b.1 Location of Installation

Set the SDPROC in a location where it will be used. This should be a stable surface. Avoid exposing the SDPROC to damaging heat radiation from sunlight or heaters. Avoid vibration and protect the product from moisture or aggressive chemical vapors.

b.2 Electrical Connections

b.2.1 Connecting Flow Transducers

Attach the 15 pin “D” connector cable(s) between the interface panel on the rear of the SDPROC and the Flow Meter/Controller transducer(s). (Number of channels will vary from one to four in accordance with configuration and options purchased.)

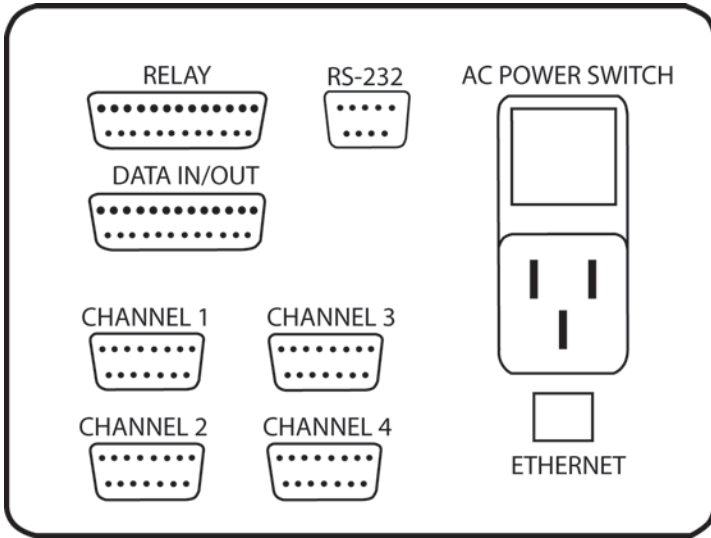

Figure b-1, Interface Panel for SDPROC.

No connection with the DATA IN/OUT, RELAYS or RS 232 connector is required for operating the system. However, it may be desirable to perform remote monitoring or control of the flow transducers. In this case, see the pin out chart for the “DATA IN/OUT” connector in step b.2.4.

⚠ Important Notes:

Assure that the “Flow Transducer” cables are used in accordance with configuration and options purchased.

In general, “D” Connector numbering patterns are standardized. There are, however, some connectors with nonconforming patterns and the numbering sequence on your mating connector may or may not coincide with the numbering sequence shown in our pin configuration table above. It is imperative that the appropriate wires are matched in accordance with the correct sequence regardless of the particular numbers displayed on your mating connector, see the pin out chart for the “Flow Transducers” connector.

Power **must be** shut OFF when connecting or disconnecting any cables in the system.

Cable lengths for Flow Transducers and DATA IN/OUT may not exceed 9.5 feet (3 meters).

Use of the SDPROC in a manner other than that specified in this manual or in writing from Aalborg®, may impair the protection provided by the equipment.

PIN	FUNCTION	PIN	FUNCTION
1	Chassis Ground	9	Control Set Point Input 0-5 Vdc
2	Common, Signal Ground for pin 3	10	Common, Signal Ground for pin 9
3	0-5Vdc Flow Signal Out	11	Common, Power Supply
4	+15 Vdc Power Supply	12	Valve Purge
5	(-) 4-20 mA Flow Signal Out	13	(unassigned)
6	Reference In for Local Set Point	14	-15 Vdc Power Supply
7	(unassigned)	15	(+) 4-20 mA Flow Signal Out
8	TTL Valve Off Control	-	-

Figure b-2, Pin out chart for CHANNEL 1/2/3/4 “Flow Transducers” connector.

b.2.2 Power Input

Make sure the POWER switch on the back of the SDPROC is OFF. On one end of the AC line cord is a universal connector that will fit securely into the AC inlet receptacle at the rear of the SDPROC. Make this connection. Per your specifications at the time of your order, on the opposite end of the AC line cord is a plug compatible with the AC power receptacle you intend to use for AC power supply. Make this connection to the AC power supply receptacle. The SDPROC is capable of receiving 85VAC to 240VAC and 50/60Hz power without any need for jumpering or compensation.

⚠ Use only the AC power line cord supplied with the instrument. Do not attempt to force or manipulate the plugs of the AC line cord in any way. If it does not fit easily and securely, contact your distributor or Aalborg®.

b.2.3 Applying Power to the SDPROC

Turn the POWER switch to the ON position. A start up display will be briefly visible, and will display the type of SDPROC configuration for the given unit. See the OPERATING INSTRUCTIONS section of this manual for details on controls and displays.

b.2.4 Remote Signal Interface

At the rear of the SDPROC, there is a 25 pin Female Type “D” connector “DATA IN/OUT”. The pin outs are as follows, (**NOTE:** “External Set Point Reference” is only applicable to mass flow controllers).

PIN	FUNCTION	PIN	FUNCTION
1	Chassis	14	Ground - Common
2	External Set Point Reference Ch4	15	Ground - Common
3	0-5VDC Flow Output Ch4	16	Ground - Common
4	4-20mA Flow Output Ch4	17	Return 4-20mA Flow Output Ch4
5	External Set Point Reference Ch3	18	Ground - Common
6	4-20mA Flow Output Ch3	19	Return 4-20mA Flow Output Ch3
7	0-5VDC Flow Output Ch3	20	Ground - Common
8	External Set Point Reference Ch2	21	Ground - Common
9	0-5VDC Flow Output Ch2	22	Ground - Common
10	4-20mA Flow Output Ch2	23	Ground - Common
11	External Set Point Reference Ch1	24	Return 4-20mA Flow Output Ch2
12	0-5VDC Flow Output Ch1	25	Return 4-20mA Flow Output Ch1
13	4-20mA Flow Output Ch1	-	-

Turn the POWER OFF when not in use.

At the rear of the SDPROC, there is a 25 pin Male Type “D” connector “RELAYS”. The pin outs are as follows:

b.2.5 Relays Interface

	<u>FUNCTION</u>		<u>PIN</u>	<u>FUNCTION</u>
13	Chassis		25	NC Relay #1
12	COM Relay #1		24	COM Relay #2
11	NO Relay #1		23	NO Relay #2
10	NC Relay #2		22	NC Relay #3
9	COM Relay #3		21	COM Relay #4
8	NO Relay #3		20	NO Relay #4
7	NC Relay #4		19	NC Relay #5
6	COM Relay #5		18	COM Relay #6
5	NO Relay #5		17	NO Relay #6
4	NC Relay #6		16	NC Relay #7
3	COM Relay #7		15	COM Relay #8
2	NO Relay #7		14	NO Relay #8
1	NC Relay #8		-	-

(c) DESCRIPTION

Microprocessor driven digital Command Modules are used in conjunction with any analog or digital mass flow meters or controllers with 0-5 Vdc input /output signals. One, two, three and four channel Command Module configurations are available. Command Modules contain appropriate power supplies, 24x2 alpha-numeric dot matrix display readout, and four panel buttons which provide complete control over all the various functions necessary to measure and/or control flow. All channels may be simultaneously monitored from output signals to a data acquisition or external monitoring device. **RS-232** serial communication interface is standard for all models and supported via a 9 pin “D”-connector at the back panel of the Command Module. RS-232 Software interface commands set allows communications with the unit using either a custom software program or a “dumb terminal” and provide complete control over all modes and functions. Optional built-in Ethernet interface allows accessing any Internet-connected SDPROC from a browser on your work station, PC, or laptop computer. **Regardless of where you are, your Command Module is as close as the nearest browser!** There are two levels of Web-based Remote Controls: HTML web server and TELNET. The flow set points, measured gas flow and associated totalizer data are scaled directly in engineering units via front panel keypad, RS-232 or Ethernet interface. The following units of measure are supported: %F.S., SLPM, SLPH, SCCM, SCCH, SCFM, SCFH, SCMM, SCMH, LBPM, LBPH, GRPM, GRPH (**NOTE:** In order to use mass based engineering units proper value of the gas density has to be set for corresponding channel).

(d) SPECIFICATIONS

ENVIRONMENTAL (PER IEC 664): Installation Level II; Pollution Degree II

POWER SUPPLY: 85 to 264 VAC (47 to 63 Hz) 2A max.

FUSE: 2A on input and output power line. When changing, unplug the device from power source. Replace only with fuse 5mm 2A/250V FF.

DISPLAY: 24x2 LCD dot matrix with backlight; 24x2 Vacuum Florescent display optional.

READINGS: 0 to 100% scale is standard; the following units of measure are supported: %F.S., SLPM, SLPH, SCCM, SCCH, SCFM, SCFH, SCMM, SCMH, LBPM, LBPH, GRPM, GRPH.

ADC/DAC RESOLUTION: 12 bits (0.025%).

DIGITAL COMMUNICATION STANDARD: RS-232.

Optional: Ethernet TCP/IP (HTML Server or TELNET Console).

RS-232 COMMUNICATIONS PARAMETERS: 8 bits, two stop bits, no parity (8,2,N).

RS-232 DATA TRANSFER RATE: 9600 baud.

CONTACT CLOSURES: Two sets of dry contact relay outputs for each channel (0.5A at 125 Vac, 1A at 24 Vdc).

BUZZER: Piezo Audio Indicator at 3.0 KHz, 85 dB activated by Alarm or Totalizer.

DIMENSIONS: Length: 7.75 inch (19.5cm), width: 6.75 inch (17cm), height: 4.5 inch (11cm).

WEIGHT: 6.00 lbs (1.8kg).

TRANSDUCER INTERFACE CABLE: Flat cable with 15 pin “D” connector on the ends is standard for AFC series mass flow controllers. Optional round shielded cable is available with male/female “D” connector ends for customer’s mass flow meters or controllers. [Cable length may not exceed 9.5 feet (3 meters)].

RELAYS PORT CABLE: Optional shielded cable with female 25 pin “D” connector to connect to command module relays port.

DATA PORT CABLE: Optional shielded cable with male 25 pin “D” connector to connect to command module data port. [Cable length may not exceed 9.5 feet (3 meters)].

d.1 CE Compliance

Any SDPROC are in compliance with the below stated test standards currently accepted.

EMC Compliance with 89/336/EEC as amended;

CE COMPLIANCE: EN 50011:1998 Group 1, Class A August 1999 for emissions; EN 61000-6-1:2001 for immunity.

(e) OPERATING INSTRUCTIONS

There are four buttons on the front panel of the SDPROC from which all functions can be controlled or set. These are labeled “ESC”, “UP”, “DOWN”, and “ENTER”.

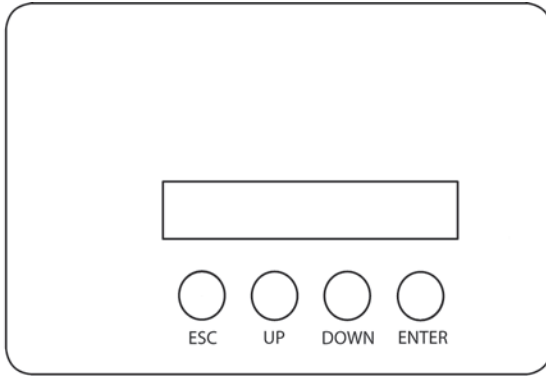

Figure e-1, Control Panel for SDPROC.

e.1 Preparation and Warm Up

It is assumed that the SDPROC and the Mass Flow Meter(s) and/or Controller(s) have been correctly installed as described in this and the AFM/AFC/DFC/GFM/GFC manuals.

Turn the POWER switch to the ON position. A start up display will be briefly visible, and will display the type SDPROC configuration for the given unit. Remember to allow for proper warm up time by the mass flow transducer.

e.2 Single Channel SDPROC

e.2.1 Start up Display

Switching the power ON, the following will be shown on the display at the front of the SDPROC.

```
A A L B O R G   I N S T R U M E N T S
S D P R O C 1   V 1 . 0 2   0 3 / 3 0 / 2 0 0 3
```

e.2.2 Main Display

After a few seconds, the Start up display will clear and the Main Display will appear.

```
F = 5 0 . 0 % I   S = 5 0 . 0 %   V = A U T
A = D           T O T A L =           8 2 5 . 7   L
```

This display will remain active until the power is turned off or any button is pressed.

The Main Display will indicate the following info:

- “F” current flow rate in % F.S. (**NOTE:** An “I” is indicated on the display immediately following the displayed flow when the SDPROC is set for internal reference and “E” for external reference.)
- “S” current set point in % F.S.
- “V” valve status by displaying a “CLS” for CLOSE, “OPN” for OPEN or “AUT” for AUTO.
- “A” alarm status by displaying a “D” for disabled, “N” for no alarm events, “L” for Low alarm and “H” for High alarm.
- “TOTAL” totalizer reading in current (volume/mass based) Engineering Units.

Readings are linear 0 to 100% of full scale. Direct engineering units are available on another screen. A proportionally linear 0 to 5 VDC or 4 to 20 mA output signal may be monitored simultaneously at the 25 pin “D” connector at the rear of the SDPROC (see section b.2.4). Press the Down button under the Main Display screen, to set the GENERAL, ALARM, TOTALIZER and PROGRAM settings (see section e.2.6).

e.2.3 Control Mode Status

There are three modes of operation that the mass flow controller can be set for. CLOSE will shut off the power to the mass flow controller valve, allowing the valve to mechanically close. OPEN will provide maximum power to the valve to allow it to open fully. This mode is used when there is a need to purge the gas flow system. AUTO mode will allow the mass flow controller to maintain a given flow as set by the user. In order to change mode of operation press the Esc button from the Main Screen. The following display will appear.

V A L V E C O N T R O L			
E X I T	C L O S E	O P E N	A U T O

Valve Control Display for 1 channel SDPROC

To operate the mass flow controller in CLOSE, OPEN or AUTO modes, press the button (UP, DOWN, ENTER respectively) directly below the mode shown on the display (see section e.4.2). After pressing the button the Main Display will appear and indicate the current valve status by displaying a “CLS” for CLOSE, “OPN” for OPEN, or “AUT” for AUTO shown after the set point value.

Press the ENTER button under the Main Display screen, to set the desired flow for AUTO control.

e.2.4 Setpoint Display

The following display is shown when adjustments to the set point reference signal are desired.

F =	2 . 5 0 0	s L P M	I A S =	2 . 5 0 0
V A L V E	+		-	E X I T

Set Point Display for 1 channel SDPROC

The UP button under the “+” and DOWN button under the “-” will increase and decrease the set point respectively. Once set, press the ENTER button under EXIT on the display to return to the Main Display. This set point is only applicable when the SDPROC is used in INTERNAL REFERENCE mode. From the Set Point Screen in order to change the mode of operation press the Esc button under VALVE on the display. The following display will appear.

V A L V E :	A U T O	2 . 5 0 0	s L P M
E X I T	C L O S E	O P E N	A U T O

Valve Status/Flow Display for 1 channel SDPROC

To operate the mass flow controller in CLOSE, OPEN or AUTO modes, press the button (UP, DOWN, ENTER respectively) directly below the mode shown on the display. First line on the Display screen indicates the current valve status and flow rate in selected engineering units. Pressing the Esc button from the Valve Status/Flow Display will display Totalizer/Alarm Screen.

e.2.5 Totalizer/Alarm Display

T O T A L :		8 2 5 . 7	L
A L A R M :	D	R E S E T	E X I T

Totalizer/Alarm Display for 1 channel SDPROC

The first line of the Totalizer/Alarm screen indicates the totalizer reading in current (volume/mass based) Engineering Units. The second line shows alarm status by displaying a “D” for disabled, “N” for no alarm events, “L” for Low alarm and “H” for High alarm. The totalizer can be reset to zero by pressing the Down button under RESET on the display. Press the ENTER button under EXIT on the display in order to return in to the Main Display screen.

e.2.6 Setup Channel Display

Pressing the Down button under the Main Display screen (see section e.2.2) will display SETUP CHANNEL screen shown below.

S E T U P	C H A N N E L :		
G E N E R .	A L A R M	T O T A L	P R O G

Setup Channel screen allows to configure:

- General device settings: Int./Ext. Reference, Gas density, Engineering Units, Full Scale Flow in L/Min and Relays assignment.
- Alarm Properties: Mode, High and Low settings in % F.S., Delay Time, Action.
- Totalizer Properties: Mode, Start Flow, Stop Volume, Action.
- Program Properties: Batch parameters and Timer Settings.

Press the Esc button under GENER. on the display in order to make General settings. The following **Internal/External/Program Reference** display will appear.

e.2.6.1 Internal/External/Program Reference

R E F E R E N C E :		I N T E R N A L	
E X I T	I N T	E X T	P R G

The INT/EXT/PRG refers to point of origin for the valve control reference signal. To change this, press the button UP, DOWN, ENTER respectively. In the internal reference mode, the control signal is set by the user with the SDPROC controls (see section e.2.4).

Pressing the ENTER button on the front panel under PRG on the display of the SDPROC will toggle the reference between PROGRAM BATCH and PROGRAM TIMER. When complete with settings, press the ESC button under EXIT on the display, to go to the Density screen. The following **Setup Gas Density Display** will appear.

e.2.6.2 Setup Gas Density Display

D E N S I T Y :		1 . 2 9 3 g / L	
N E X T	+	-	- - >

The proper settings of the gas density (in grams per liter) are required for mass based engineering units (LBPH, LBPM, GrPH, GrPM). Press the ENTER button under (--->) on the display, to move the flashing cursor to the desired position. Pressing (+) or (-) will increment or decrement the particular digit respectively. The numbers will change from 0 to 9 and next to decimal point (.). Pressing (+) button one more time will change highlighted position of the cursor back to 0. The same is true in backward direction when pressing the (-) button. Only one decimal point is allowed. If changing position of the decimal point is required, change decimal point to any desired digit, next move cursor to the required position and adjust it to the decimal point with (+) or (-) button.

When complete with gas density settings, press the ESC button under NEXT on the display, to go to the Engineering Units screen. The following **Setup Engineering Units Display** will appear.

e.2.6.3 Setup Engineering Units Display

```
ENGINEERING UNITS :  S L P M
NEXT          UP      DN      EXIT
```

Press the UP or DN button, to change current engineering units. The following engineering units are supported: %F.S., SLPM, SLPH, SCCM, SCCH, SCFM, SCFH, SCMM, SCMH, LBPM, LBPH, GRPM, GRPH. If no more settings are required, press the ENTER button under EXIT on the display, to go back to the Main Display. Press the ENTER button under NEXT on the display in order to go to the Full Scale Flow Rate screen. The following **Setup Full Scale Flow Rate Display** will appear.

e.2.6.4 Setup Full Scale Flow Rate Display

```
F . S . F L O W :      5 . 0 0 0  S L P M
NEXT          +      -      - - >
```

The proper settings of the Full Scale Flow Rate (in liters per minute) are required for any engineering units except % F.S. If for example a mass flow controller used with SDPROC is calibrated for 200 SCCM, the value of 0.2 has to be set. Press the ENTER button under (--->) on the display, to move the flashing cursor to the digit, which has to be adjusted. Pressing (+) or (-) will increment or decrement the particular digit respectively. The numbers will change from 0 to 9 and next to decimal point (.). Pressing (+) button one more time will change highlighted position of the cursor back to 0. The same is true in backward direction when pressing the (-) button. Only one decimal point is allowed. If changing position of the decimal point is required, change the decimal point to any desired digit, next move cursor to the required position and adjust it to decimal point with the (+) or (-) button. When complete with Full Scale Flow Rate settings, press the ESC button under NEXT on the display, to go to the Relays Assignment screen. The following **Setup Relays Assignment Display** will appear.

e.2.6.5 Setup Relays Assignment Display

```
RELAY 1 :      NO ACTION
NEXT          UP      DN      EXIT
```

Two sets of dry contact relay are available for each channel. Each relay individually can be assigned for:

- NO ACTION
- ALARM LOW
- ALARM HIGH
- TOTALIZER STOP

Press UP or DN button to change relay assignment. When complete with first relay settings, press the ESC button under NEXT on the display, to go to the second relay.

The following display will appear.

RELAY 2 :	NO	ACTION	
NEXT	UP	DN	EXIT

Press ESC button under NEXT on the display or the ENTER button under EXIT on the display, to go back to the Main Display.

e.2.7 Setup Alarm Display

Before enabling the Alarm make sure all alarm settings are configured properly. High and Low alarm values have to be entered in %F.S. engineering units. ALARM conditions become valid when the difference between current readings and installed set points is equal or more than corresponding values of high and low alarm levels. From the Setup Channel Display (see section e.2.6) press the Up button under ALARM on the display in order to make Alarm settings. The following display will appear.

ALARM MODE :	DISABLE		
NEXT	ENBL	DISBL	EXIT

e.2.7.1 Setup Alarm Mode Display

To change Alarm Mode in ENABLED or DISABLED, press the button (UP, DOWN respectively) directly below the mode shown on the display. Press the ENTER button under EXIT on the display, to go back to the Main Display. Press the ESC button under NEXT on the display to go to the Alarm Low settings. The following display will appear.

ALARM LOW :	2.0	%FS	
NEXT	+	-	EXIT

e.2.7.2 Setup Alarm Low Display

Pressing (+) or (-) will increment or decrement Low Alarm settings per 0.1% F.S. respectively. If no settings required for High Alarm press the ENTER button under EXIT on the display, to go back to the Main Display. Press the ESC button under NEXT on the display to go to the Alarm High settings. The following display will appear.

ALARM HIGH :	2.0	%FS	
NEXT	+	-	EXIT

e.2.7.3 Setup Alarm High Display

Pressing (+) or (-) will increment or decrement High Alarm settings per 0.1% F.S. respectively. If no settings are required for High Alarm press the ENTER button under EXIT on the display, to go back to the Main Display. Press the ESC button under NEXT on the display to go to the Alarm Delay settings. The following **Setup Alarm Delay Display** will appear.

e.2.7.4 Setup Alarm Delay Display

A L A R M	D E L A Y :	0	S e c
N E X T	+	-	E X I T

Alarm Delay specifies the time interval in seconds the Alarm conditions have to be True (without any interruption) before Alarm will be activated. If zero value is set, the Alarm will be activated immediately after Alarm conditions are met. Pressing (+) or (-) will increment or decrement Alarm Delay settings per 1 second respectively. If no settings required for Alarm Action press the ENTER button under EXIT on the display, to go back to the Main Display. Press ESC button under NEXT on the display go to the Alarm Action settings. The following **Setup Alarm Action Display** will appear.

e.2.7.5 Setup Alarm Action Display

A L A R M	A C T I O N :	N O N E	
N O N E	B U Z Z E R	V A L V E	E X I T

To change Alarm Action in NONE, BUZZER or VALVE, press the button (ESC, UP, DOWN respectively) directly below the text shown on the display. If Buzzer action is chosen, the audible signal will be activated when Alarm conditions become true.

 In order to deactivate the audible signal during operation press any button on the key pad.
(NOTE: The Alarm Conditions have to be removed or Alarm has to be disabled).

If Valve action is chosen the power to the mass flow controller valve will be shut off, allowing the valve to mechanically close.

 If the Valve was shut off as a result of the Alarm action, in order to go back to normal operation the Valve mode has to be changed to AUTO (See section e.2.3). **NOTE:** The Alarm Conditions have to be removed, or Alarm has to be disabled prior to any attempts to change the Valve mode.

To go back to the Main Display, press the ENTER button under EXIT on the display.

e.2.8 Setup Totalizer Display

Before enabling the Totalizer make sure that all totalizer settings are configured properly. The totalizer Start value has to be entered in %F.S. engineering units. Totalizer will not totalize until the flow rate become equal or more than Totalizer Start value. Totalizer Stop value has to be entered in volume / mass based engineering units. Totalizer conditions become valid when the totalized volume is equal or more than Totalizer Stop value. From the Setup Channel Display (see section e.2.6) press Down button under TOTAL on the display in order to make Totalizer settings. The following **Setup Totalizer Mode Display** will appear.

e.2.8.1 Setup Totalizer Mode Display

T O T A L I Z E R	M O D E :	D I S A B L E
N E X T	E N B L	D I S B L E X I T

To change Totalizer Mode in ENABLED or DISABLED, press the button (UP, DOWN respectively) directly below the mode shown on the display. To return to the Main Display, press the ENTER button under EXIT on the display. Press the ESC button under NEXT on the display to go to the Totalizer Start settings. The following **Setup Totalizer Start Flow Display** will appear.

e.2.8.2 Setup Totalizer Start Flow Display

T O T A L I Z E R	S T A R T :	2 . 0 %
N E X T	+	- E X I T

Pressing (+) or (-) will increment or decrement Totalizer Start settings per 0.1% F.S. respectively. If no settings are required for Totalizer Stop value press the ENTER button under EXIT on the display, to go back to the Main Display. Press ESC button under NEXT on the display to go to the Totalizer Stop settings. The following **Setup Totalizer Stop Volume Display** will appear.

e.2.8.3 Setup Totalizer Stop Volume Display

T O T A L I Z E R	S T O P :	1 0 0 0 0 0 . 0
N E X T	+	- - - >

The proper settings of the Totalizer Stop Volume (in volume/mass based engineering units) is required if the Totalizer is set to Enabled. The engineering unit for Totalizer Stop Volume has to be related to the current active engineering unit. If for example current engineering unit is sLPM, the Totalizer Stop Volume has to be entered in liters. Press the ENTER button under (--->) on the display, to move the flashing cursor to the digit, which has to be adjusted. Pressing (+) or (-) will increment or decrement the particular digit respectively. The numbers will change from 0 to 9 and next to the decimal point (.). Pressing the (+) button one more time will change the highlighted position of the cursor back to 0. The same is true in reverse direction when pressing the (-) button. Only one decimal point is allowed. If changing the position of the decimal point is required, change decimal point to any desired digit, then move the cursor to the required position, and adjust it to the decimal point with (+) or (-) button. When complete with Totalizer Stop Volume settings, press the ESC button under NEXT on the display, to go to the Totalizer Action screen. The following **Setup Totalizer Action Display** will appear.

e.2.8.4 Setup Totalizer Action Display

T O T A L I Z E R	A C T I O N :	N O N E
N O N E	B U Z E R	V A L V E E X I T

To change Totalizer Action in NONE, BUZZER or VALVE, press the button (ESC, UP, DOWN respectively) directly below the text shown on the display. If Buzzer action is chosen, the audible signal will be activated when Totalizer conditions become true.

⚠ In order to deactivate the audible signal during operation press any button on the key pad (**NOTE:** The Totalizer has to be reset to zero or disabled).

If Valve action is chosen, the power to the mass flow controller valve will be shut off, allowing the valve to mechanically close.

⚠ If the Valve was shut off as a result of the Totalizer action, in order to go back to normal operation the Valve mode has to be changed to AUTO (See section e.2.3). **NOTE:** The Totalizer reading has to be reset to zero or Totalizer has to be disabled prior any attempts to change the Valve mode.

To return to the Main Display, press the ENTER button under EXIT on the display.

e.2.9 Program Settings Display

From the Setup Channel Display (see section e.2.6) press the Enter button under PROG on the display in order to make Program settings. The following display will appear. There are two program options: BATCH and TIMER flow control.

e.2.9.1 Batch Program Settings Display

P R O G R A M			S E T T I N G S		
E X I T			B A T C H		T I M E R

The Batch Flow Control allows execution of custom, user preset programs of up to sixteen steps. During execution of the program the user can activate or deactivate the LOOP mode. Various flow configurations may be preprogrammed: ramping, pulsing, linearized increasing and/or decreasing of the flow. Before executing, the program should be entered in the program table in the format: SETPOINT [% F.S.] - TIME [sec.]. TIME means: time it takes for the value of the output signal from mass flow controller to linearly approach the SETPOINT value (ramping). Press the DOWN button under BATCH on the display, to set up the BATCH table. The following display will appear.

S T	1	T I M E :	0	S E C	M	1
N E X T		+	-			M U L T

Time Settings for first step of the BATCH table

Pressing (+) or (-) will increment or decrement the step time settings per 1, 10 or 100 seconds (depending on the value of the multiplier M) respectively. The maximum valid value is 99999 seconds. Pressing the (+) button one more time will rollover time settings to zero.

The same is true for 0 seconds, pressing the (-) button will rollover time settings to 99999 seconds. Press the ENTER button under MULT on the display, to change the value of the multiplier to 10. Continuing to press the ENTER button under MULT on the display, will change the value of the multiplier first to 100 and then back to 1. When complete with TIME settings for the first step of the Batch program, press the ESC button under NEXT on the display, to go to the SETPOINT screen. The following display will appear.

```

S T 1   S E T P O I N T :   0 . 0   % F S
E X I T       +           -           N E X T
  
```

Set Point Settings for first step of the BATCH table

Pressing (+) or (-) will increment or decrement the step set point settings per 0.1% F.S. respectively. When complete with SET POINT settings for the first step of the Batch program, press the ENTER button under NEXT on the display, to go to the next step. Continue with Time and Set point settings for as many steps as required for your application (16 is the maximum limit). When complete with all settings for the Batch program press the Esc button under EXIT on the display, to go to the BATCH control screen. The following display will appear.

```

S E : 1 6   B A T C H : O F F   L O O P : O F F
E X I T     S T E P S     S T A R T   L O O P
  
```

BATCH mode control screen with batch disabled

The two digit numbers after “SE:” indicate the number of the enabled steps for executions. Press the UP button under STEPS on the display, to change number of steps from the batch program to be executed. With 16 steps enabled on the screen, pressing the Up button one more time will rollover the number of steps back to 1. Press the ENTER button under LOOP on the display, to toggle the loop control ON and OFF. If loop control is ON, after executing the last enabled step, the program will go back to the first step and go on again until the loop mode will be disabled. **NOTE:** In order to start batch program executions, press the Down button under START on the display. **NOTE:** In order to execute a batch program, the valve control reference has to be set to BATCH mode (See section e.2.6.1). The following display will appear.

```

S E : 1 6   B A T C H :   O N   L O O P : O F F
E X I T     S T E P S     S T O P   L O O P
  
```

BATCH mode control screen with batch enabled

Press the Down button under STOP on the display one more time, to toggle the batch mode to OFF (disabled). Press the Esc button under EXIT on the display, to go to the Main Display.

e.2.9.2 Timer Program Settings Display

The Timer Flow Control allows execution of a custom, user preset program of up to 96 steps. Each step can be pre-programmed for a particular date, time, and set point value in % F.S.. Every step has two fields: starting date, time and set point in % F.S. Before executing, the program should be entered in the program table in the format: TIME/DATE [XX.XX XX/XX/XXXX] - SETPOINT [% F.S.]. Time and date indicates exact moments (+/- one minute accuracy) when the set point has to be executed by the mass flow controller. From the Program Settings Display (See section e.2.9), press the Enter button under TIMER on the display, to set up the TIMER table. The following display will appear.

S T E P :	1	1 3	:	0 4	0 4 / 0 7 / 2 0 0 3
N E X T		+		-	- - >

Time and date settings for first step of the TIMER table

Press ENTER button under (--->) on the display, to move flashing cursor to the hours position. Pressing (+) or (-) will increment or decrement the time settings (hours). When complete with hours settings press again ENTER button to move the flashing cursor to the minutes position. When done with time settings press again ENTER button to move the flashing cursor to the date position (month, date and year) respectively.

⚠ Make sure date and time entered is not in the past (otherwise this step of the program will not be executed).

When complete with TIME and DATE settings for first step of the Timer program, press the ESC button under NEXT on the display, to go to the SETPOINT screen. The following display will appear

T M R	S T E P :	1	S P :	0 . 0 % F S	
E X I T		+		-	N E X T

Set Point settings for first step of the TIMER table

Pressing (+) or (-) will increment or decrement the step set point settings per 0.1% F.S. respectively. When complete with SET POINT settings for the first step of the Timer

program, press the ENTER button under NEXT on the display, to go to the next step. Continue with Time/Date and Set point settings for as many steps as required for your application (96 is maximum limit). When complete with all settings for the Timer program press the Esc button under EXIT on the display, to go to the Main Display screen.

⚠ Make sure the reference for set point is set to PROGRAM TIMER mode in order for the Timer program to be executed (see section e.2.6.1).

e.2.10 Status Check

While in the Main Display press the UP button on the front panel of the SDPROC. The Relays Assignment Status will appear.

```
RELAYS SETTINGS :  
# 1 = NO ACTION 2 = NO ACTION
```

Relays Status Display One channel SDPROC

Pressing the UP button again will bring up the Totalizer Settings screen. Pressing the DOWN button will return to the Main Display.

```
TOTAL = DIS ` D START = 2 . 0 %  
STOP = 100000 . 0 L
```

Totalizer Settings Display One channel SDPROC

Press UP one more time to return to the Main Display.

E.3 MULTI CHANNEL SDPROC

e.3.1 Start up Display

Switching the power ON, the following will be shown on the display at the front of the SDPROC.

```
AALBORG INSTRUMENTS  
SDPROC2 V1.02 03/30/2003
```

Start up Display for 2 channel SDPROC

```
AALBORG INSTRUMENTS  
SDPROC3 V1.02 03/30/2003
```

Start up Display for 3 channel SDPROC

```
AALBORG INSTRUMENTS  
SDPROC4 V1.02 03/30/2003
```

Start up Display for 4 channel SDPROC

e.3.2 Main Display

After a few seconds, the Start up display will clear, and the Main Display will appear.

# 1 = 1 0 0 . 0 % I	# 2 = 5 0 . 0 % I
---------------------	-------------------

Main Display for 2 channel SDPROC

# 1 = 1 0 0 . 0 % I	# 2 = 5 0 . 0 % I
# 3 = 7 5 . 0 % I	

Main Display for 3 channel SDPROC

# 1 = 1 0 0 . 0 % I	# 2 = 5 0 . 0 % I
# 3 = 7 5 . 0 % I	# 4 = 2 5 . 0 % I

Main Display for 4 channel SDPROC

Readings are linear 0 to 100% of full scale. Direct engineering units are available on another screen. A proportionally linear 0 to 5 VDC or 4 to 20 mA output signal may be monitored simultaneously at the 25 pin "D" connector at the back of the SDPROC (see section b.2.4). Press the Down button under the Main Display screen, to set the GENERAL, ALARM, TOTALIZER and PROGRAM settings (see section e.3.6).

e.3.3 Channel Select

There are three modes of operation that the mass flow controller can be set for. CLOSE will shut off the power to the mass flow controller valve, allowing the valve to mechanically close. OPEN will provide maximum power to the valve to allow it to open fully. This mode is used when there is a need to purge the gas flow system. AUTO mode will allow the mass flow controller to maintain a given flow as set by the user or program. Each channel is independent of the other, and therefore each will need to be set.

The basic display/menu elements for the two, three, and four channel SDPROC's are essentially identical with the exception of the number of channels available.

To operate the mass flow controller in CLOSE, OPEN or AUTO modes, press the ENTER button directly below the display screen.

S E L E C T C H A N N E L			
1	2	3	4

Channel Select Display Multi channel SDPROC

Press the button on the SDPROC panel under the appropriate channel number displayed. This will select that channel for control configuration. (For this manual, chan-

nel 3 has been selected.) The following **Set Point Display** will appear.

e.3.4 Set Point Display

C H 3	S P :	I	3 . 7 5 0	S L P M
N E X T		+	-	E X I T

Set point Display Multi channel SDPROC

The screen above assumes that the full scale flow rate for channel #3 is set to 5.0 SLPM and current units of measure is SLPM. The UP button under the “+” and DOWN button under the “-” will increase and decrease the set point respectively. This set point is only applicable when the SDPROC is used in INTERNAL REFERENCE mode (**NOTE:** the character after “SP:” indicates current status for set point reference.)

When complete with the set point setting, press the ESC button under NEXT on the display, to proceed to the Control Mode Display or the ENTER button under EXIT on the display, to go to the Main Display.

e.3.5 Control Mode Display

C H 3	A U T O	3 . 7 5 0	S L P M
E X I T	C L O S E	O P E N	A U T O

Control Mode Display Multi channel SDPROC

To operate the mass flow controller in CLOSE, OPEN or AUTO modes, press the button (UP, DOWN, ENTER respectively) directly below the mode shown on the display. First line on the Display screen indicates the current valve status and flow rate in selected engineering units. Pressing the Esc button under NEXT on the display from the Control Mode Display, will display the Totalizer /Alarm Screen for channel #3.

e.3.6 Totalizer/Alarm Status Display

C H 3	T O T A L :	8 2 5 . 7	L
A L A R M :	D	R E S E T	E X I T

Totalizer/Alarm Status Display for Multi channel SDPROC

The first line of the Totalizer/Alarm screen indicates the totalizer reading in current (volume/mass based) Engineering Units. The second line shows alarm status by displaying a “D” for disabled, “N” for no alarm events, “L” for Low alarm and “H” for High alarm. The totalizer can be reset to zero by pressing the Down button under RESET on the display. Press the ENTER button under EXIT on the display in order to return to the Main Display screen. Press the Esc button under CH3 on the display in order to return to the Set Point screen for channel #3.

e.3.7 Setup Channel Display

Pressing the Down button under Main Display screen (see section e.3.2) will display SETUP CHANNEL screen shown below.

```
      S E T U P   C H A N N E L :  
      1           2           3           4
```

Setup Channel Display for Multi channel SDPROC

Press the button on the SDPROC panel under the appropriate channel number displayed. This will select that channel for device settings configuration. (For this manual, channel 3 has been selected.) The following display will appear.

```
      C H A N N E L :   3  
G E N E R .   A L A R M   T O T A L   P R O G
```

Setup Channel screen allows to configure:

- GENERAL DEVICE SETTINGS: Int./Ext. Reference, Gas density, Engineering Units, Full Scale Flow in L/Min and Relays assignment.
- ALARM PROPERTIES: Mode, High and Low settings in % F.S., Delay Time, Action.
- TOTALIZER PROPERTIES: Mode, Start Flow, Stop Volume, Action.
- PROGRAM PROPERTIES: Batch parameters, Timer and Ratio Settings.

Press the Esc button under GENER on the display in order to make General settings. The following **Internal/External/Program Reference** display will appear.

e.3.7.1 Internal/External/Program Reference

The INT/EXT/PRG refers to point of origin for the valve control reference signal. To change this, press the button UP, DOWN, ENTER respectively. In the internal reference

```
      C H 3   R E F E R E N C E :       I N T E R N A L  
      E X I T           I N T           E X T           P R G
```

mode, the control signal is set by the user with the SDPROC controls (see section e.3.4). In external reference mode, the control signal is set by the user from a remote location. This external reference signal is provided for via the DATA IN/OUT 25 pin "D" connector at the rear of the SDPROC (see section b.2.4).

Pressing the ENTER button on the front panel under PRG on the display of the SDPROC will toggle the reference between PROGRAM BATCH, PROGRAM TIMER and RATIO. When complete with settings, press the ESC button under EXIT on the display, to go to the Density screen. The following **Setup Gas Density Display** will appear.

e.3.7.2 Setup Gas Density Display

C H 3	D E N S I T Y :	1 . 2 9 3	g / L
N E X T	+	-	- - >

The proper settings of the gas density (in grams per liter) are required for mass based engineering units (LBPH, LBPM, GrPH, GrPM). Press the ENTER button under (--->) on the display, to move the flashing cursor to the desired position. Pressing (+) or (-) will increment or decrement a particular digit respectively. The numbers will change from 0 to 9 and next to the decimal point (.). Pressing the (+) button one more time will change the highlighted position of the cursor back to 0. The same is true in reverse: when pressing the (-) button. Only one decimal point is allowed. If changing the position of the decimal point is required, change the decimal point to any desired digit, then move the cursor to the required position and adjust it to the decimal point with (+) or (-) button.

When complete with gas density settings, press the ESC button under NEXT on the display, to go to the Engineering Units screen. The following **Setup Engineering Units Display** will appear.

e.3.7.3 Setup Engineering Units Display

C H 3	E N G I N E E R . U N I T S :	S L P M	
N E X T	U P	D N	E X I T

Press the UP or DN button, to change current engineering units. The following engineering units are supported: %F.S., SLPM, SLPH, SCCM, SCCH, SCFM, SCFH, SCMM, SCMH, LBPM, LBPH, GRPM, GRPH. If no more settings are required, press the ENTER button under EXIT on the display, to go back to the Main Display. Press the ENTER button under NEXT on the display in order to go to the Full Scale Flow Rate screen. The following **Setup Full Scale Flow Rate Display** will appear.

e.3.7.4 Setup Full Scale Flow Rate Display

C H 3	F S	F L O W :	5 . 0 0 0	S L P M
N E X T	+	-	- - >	

The proper settings of the Full Scale Flow Rate (in liters per minute) are required for any engineering units except % F.S. If for example a mass flow controller used with channel #3 of the SDPROC is calibrated for 200 SCCM, the value of 0.2 has to be set. Press the ENTER button under (--->) on the display, to move the flashing cursor to the digit, which has to be adjusted. Pressing (+) or (-) will increment or decrement a particular digit respectively. The numbers will change from 0 to 9 and next to the decimal point (.). Pressing the (+) button one more time will change the highlighted position of the cursor back to 0. The same is true in reverse, when pressing the (-) button. Only one decimal point is allowed. If changing the position of the decimal point is required,

change the decimal point to any desired digit, next move the cursor to the required position, and adjust it to the decimal point with the (+) or (-) button. When complete with Full Scale Flow Rate settings, press the ESC button under NEXT on the display, to go to the Relays Assignment screen. The following **Setup Relays Assignment Display** will appear.

e.3.7.5 Setup Relays Assignment Display

C H 3	R E L A Y	1 :	N O	A C T I O N
N E X T	U P	D N	E X I T	

Two sets of dry contact relay are available for each channel. Each relay individually can be assigned for:

- NO ACTION
- ALARM LOW
- ALARM HIGH
- TOTALIZER STOP

Press either the UP or DN button to change the relay assignment. When complete with the first relay settings, press the ESC button under NEXT on the display, to go to the second relay. The following display will appear.

C H 3	R E L A Y	2 :	N O	A C T I O N
N E X T	U P	D N	E X I T	

Press the ESC button under NEXT on the display or the ENTER button under EXIT on the display, to go back to the Main Display.

e.3.8 Setup Alarm Display

Before enabling the Alarm make sure all alarm settings are configured properly. High and Low alarm values have to be entered in %F.S. engineering units. ALARM conditions become valid when the difference between current readings and installed set points is equal or more than corresponding values of high and low alarm levels. From the Setup Channel Display (see section e.3.7) press the Up button under ALARM on the display in order to make Alarm settings. The following **Setup Alarm Mode Display** will appear.

e.3.8.1 Setup Alarm Mode Display

C H 3	A L A R M	M O D E :	D I S A B L E
N E X T	E N B L	D I S B L	E X I T

To change the Alarm Mode in ENABLED or DISABLED, press the button (UP, DOWN respectively) directly below the mode shown on the display. Press the ENTER button under EXIT on the display, to go back to the Main Display. Press the ESC button under

NEXT on the display to go to the Alarm Low settings. The following **Setup Alarm Low Display** will appear.

e.3.8.2 Setup Alarm Low Display

C H 3	A L A R M	L O W :	2 . 0	% F S
N E X T		+	-	E X I T

Pressing (+) or (-) will increment or decrement Low Alarm settings per 0.1% F.S. respectively. If no settings are required for High Alarm press the ENTER button under EXIT on the display, to go back to the Main Display. Press the ESC button under NEXT on the display to go to the Alarm High settings. The following **Setup Alarm Low Display** will appear.

e.3.8.3 Setup Alarm High Display

C H 3	A L A R M	H I G H :	2 . 0	% F S
N E X T		+	-	E X I T

Pressing (+) or (-) will increment or decrement High Alarm settings per 0.1% F.S. respectively. If no settings are required for High Alarm press the ENTER button under EXIT on the display, to go back to the Main Display. Press the ESC button under NEXT on the display to go to the Alarm Delay settings. The following **Setup Alarm Delay Display** will appear.

3.8.4 Setup Alarm Delay Display

C H 3	A L A R M	D E L A Y :	0	S e c
N E X T		+	-	E X I T

Alarm Delay specifies the time interval in seconds the Alarm conditions have to be True (without any interruption) before the Alarm will be activated. If zero value is set, the Alarm will be activated immediately after Alarm conditions are met. Pressing (+) or (-) will increment or decrement Alarm Delay settings per 1 second respectively. If no settings are required for Alarm Action press the ENTER button under EXIT on the display, to go back to the Main Display. Press the ESC button under NEXT on the display to go to the Alarm Action settings. The following **Setup Alarm Action Display** will appear.

e.3.8.5 Setup Alarm Action Display

C H 3	A L A R M	A C T I O N :	N O N E	
N O N E	B U Z Z E R	V A L V E	E X I T	

To change Alarm Action in NONE, BUZZER or VALVE, press the button (ESC, UP, DOWN respectively) directly below the text shown on the display. If Buzzer action is chosen the audible signal will be activated when Alarm conditions become true.

⚠ In order to deactivate the audible signal during operation, press any button on the key pad (**NOTE:** Alarm Conditions have to be removed or Alarm for the corresponding channel has to be disabled).

If Valve action is chosen the power to the mass flow controller valve will be shut off, allowing the valve to mechanically close.

⚠ If the Valve was shut off as the result of the Alarm action, in order to go back to normal operation the Valve mode has to be changed to AUTO (See section e.3.5).
NOTE: Alarm Conditions have to be removed or Alarm has to be disabled prior any attempts to change the Valve mode.

Press the ENTER button under EXIT on the display, to go back to the Main Display.

e.3.9 Setup Totalizer Display

Before enabling the Totalizer ensure that all totalizer settings are configured properly. Totalizer Start values have to be entered in %F.S. engineering units. Totalizer will not totalize until the flow rate becomes equal or more than the Totalizer Start value. Totalizer Stop values have to be entered in volume / mass based engineering units. Totalizer condition becomes valid when the totalized volume is equal or more than the Totalizer Stop value.

From the Setup Channel Display (see section e.3.7) press the Down button under TOTAL on the display in order to make Totalizer settings. The following **Setup Totalizer Mode Display** will appear.

e.3.9.1 Setup Totalizer Mode Display

C H 3	T O T A L	M O D E :	D I S A B L E
N E X T	E N B L	D I S B L	E X I T

To change the Totalizer Mode in ENABLED or DISABLED, press the button (UP, DOWN respectively) directly below the mode shown on the display. Press the ENTER button under EXIT on the display, to go back to the Main Display. Press the ESC button under NEXT on the display to go to the Totalizer Start settings. The following **Setup Totalizer Start Flow Display** will appear.

e.3.9.2 Setup Totalizer Start Flow Display

C H 3	T O T A L	S T A R T :	2 . 0	%
N E X T		+	-	E X I T

Pressing (+) or (-) will increment or decrement Totalizer Start settings per 0.1% F.S. respectively. If no settings are required for Totalizer Stop value press the ENTER button under EXIT on the display, to go back to the Main Display. Press the ESC button

under NEXT on the display to go to the Totalizer Stop settings. The following **Setup Totalizer Stop Volume Display** will appear.

e.3.9.3 Setup Totalizer Stop Volume Display

C H 3	T O T A L	S T O P :	1	0	0	0	0	0	.	0
N E X T			+						-	- >

The proper setting of the Totalizer Stop Volume (in volume/mass based engineering units) is required if the Totalizer is set to Enabled. The engineering unit for Totalizer Stop Volume has to be related to the current active engineering unit. If for example the current engineering unit is sLPM, the Totalizer Stop Volume has to be entered in liters. Press the ENTER button under (--->) on the display, to move the flashing cursor to the digit, which has to be adjusted. Pressing (+) or (-) will increment or decrement a particular digit respectively. The numbers will change from 0 to 9 and next to the decimal point (.). Pressing the (+) button one more time will change the highlighted position of the cursor back to 0. The same is true in reverse, when pressing the (-) button. Only one decimal point is allowed. If changing position of the decimal point is required, change decimal point to any desired digit then move the cursor to the required position and adjust it to the decimal point with (+) or (-) button. When complete with Totalizer Stop Volume settings, press the ESC button under NEXT on the display, to go to the Totalizer Action screen. The following **Setup Totalizer Action Display** will appear.

e.3.9.4 Setup Totalizer Action Display

C H 3	T O T A L	A C T I O N :	N	O	N	E
N O N E	B U Z Z E R	V A L V E	E	X	I	T

To change the Totalizer Action in NONE, BUZZER or VALVE, press the button (ESC, UP, DOWN respectively) directly below the text shown on the display. If Buzzer action is chosen the audible signal will be activated when the Totalizer condition becomes true.

⚠ In order to deactivate the audible signal during operation press any button on the key pad (**NOTE:** The Totalizer has to be reset to zero or disabled).

If Valve action is chosen, the power to the mass flow controller valve will be shut off, allowing the valve to mechanically close.

⚠ If the Valve was shut off as result of the Totalizer action, in order to go back to normal operation the Valve mode has to be changed to AUTO (See section e.3.5).
NOTE: The Totalizer reading has to be reset to zero or the Totalizer has to be disabled prior any attempts to change the Valve mode.

Press the ENTER button under EXIT on the display, to go back to the Main Display.

e.3.10 Program Settings Display

From the Setup Channel Display (see section e.3.7) press the Enter button under PROG on the display in order to make Program settings. The following display will appear.

C H 3	S E T T I N G	P R O P E R T I E S
E X I T	B A T C H	T I M E R R A T I O

There are three program options for multi channel SDPROC: BATCH, TIMER and RATIO flow control.

e.3.10.1 Batch Program Settings Display

Batch Flow Control allows execution of a custom, user preset program of up to sixteen steps. During execution of the program the user can activate or deactivate the LOOP mode. Various flow configurations may be pre-programmed: ramping, pulsing, linearized increasing and/or decreasing of the flow. Before executing, the program should be entered in the program table in the format: SETPOINT [% F.S.] - TIME [sec.]. TIME means: time it takes for the value of the output signal from a mass flow controller to linearly approach SETPOINT value (ramping). Press the UP button under BATCH on the display, to set up the BATCH table. The following display will appear.

S T 1	T I M E :	0	S E C	M 1
N E X T	+	-	M U L T	

Time Settings for first step of the BATCH table

Pressing (+) or (-) will increment or decrement the step time settings per 1, 10 or 100 seconds (depending on the value of the multiplier M) respectively. The maximum valid value is 99999 seconds. Pressing the (+) button one more time will rollover time settings to zero. The same is true for 0 seconds, pressing the (-) button will rollover time settings to 99999 seconds. Press the ENTER button under MULT on the display, to change the value of the multiplier to 10. Continuing to press the ENTER button under MULT on the display, will change the value of the multiplier first to 100 and then back to 1.

When complete with TIME settings for the first step of the Batch program, press the ESC button under NEXT on the display, to go to the SETPOINT screen.

The following display will appear.

S T 1	S E T P O I N T :	0 . 0	% F S
E X I T	+	-	N E X T

Set Point Settings for first step of the BATCH table

Pressing (+) or (-) will increment or decrement the step set point settings per 0.1% F.S. respectively. When complete with SET POINT settings for the first step of the Batch program, press the ENTER button under NEXT on the display, to go to the next step. Continue with Time and Set point settings for as many steps as required for your application (16 is maximum limit). When complete with all settings for the Batch program press the Esc button under EXIT on the display, to go to the BATCH control screen. The following display will appear.

S E : 1 6	B A T C H : O F F	L O O P : O F F
E X I T	S T E P S	S T A R T L O O P

BATCH mode control screen with batch disabled

The two digit number after “SE:” indicates the number of the enabled steps for executions. Press the UP button under STEPS on the display, to change the number of steps from the batch program to be executed. With 16 steps enabled on the screen, pressing the Up button one more time will rollover the number of steps back to 1. Press the ENTER button under LOOP on the display, to toggle the loop control ON and OFF. If loop control is ON, after executing the last enabled step, the program will go back to the first step and go on again until the loop mode will be disabled. In order to start the batch program executions, press the Down button under START on the display. **NOTE:** In order to execute the batch program, the valve control reference has to be set to BATCH mode (See section e.2.6.1). The following display will appear.

S E : 1 6	B A T C H : O N	L O O P : O F F
E X I T	S T E P S	S T O P L O O P

BATCH mode control screen with batch enabled

Press the Down button under STOP on the display one more time, to toggle the batch mode to OFF (disabled). Press the Esc button under EXIT on the display, to go to the Main Display.

e.3.10.2 Timer Program Settings Display

The Timer Flow Control allows execution of a custom, user preset program of up to 96 steps. Each step can be pre-programmed for a particular date, time, and set point value in % F.S.. Every step has two fields: starting date, time and set point in % F.S. Before executing, the program should be entered in the program table in the format: TIME/DATE [XX.XX XX/XX/XXXX] - SETPOINT [% F.S.]. Time and date indicates exact moment (+/- one minute accuracy) when the set point has to be executed by the mass flow controller. From the Program Settings Display (See section e.3.10), press the Down button under TIMER on the display, to set up the TIMER table. The following display will appear.

S T E P : 1	1 3 : 0 4	0 4 / 0 7 / 2 0 0 3
N E X T	+	- - - >

Time and date settings for first step of the TIMER table

Press the ENTER button under (--->) on the display, to move the flashing cursor to the hours position. Pressing (+) or (-) will increment or decrement the time settings (hours). When complete with hours settings press again the ENTER button to move the flashing cursor to the minutes position. When done with time settings press again

the ENTER button to move the flashing cursor to the date position (month, date and year) respectively.

⚠ Make sure date and time entered is not in the past (otherwise this step of the program will not be executed).

When complete with TIME and DATE settings for first step of the Timer program, press the ESC button under NEXT on the display, to go to the SETPOINT screen. The following display will appear.

```
T M R   S T E P :   1   S P :           0 . 0 % F S
E X I T           +           -           N E X T
```

Set Point settings for first step of the TIMER table

Pressing (+) or (-) will increment or decrement the step set point settings per 0.1% F.S. respectively. When complete with SET POINT settings for the first step of the Timer program, press the ENTER button under NEXT on the display, to go to the next step. Continue with Time/Date and Set point settings for as many steps as required for your application (96 is maximum limit). When complete with all settings for the Timer program press the Esc button under EXIT on the display, to go to the Main Display screen.

⚠ Make sure the reference for set point is set to the PROGRAM TIMER mode in order for the Timer program to be executed (see section e.3.7.1).

e.3.10.3 Ratio Program Settings Display

Ratio Flow allows controlling flow of the mixture of up to four different gases (for 4 channel Command Module) with preset values of the ratio in % for each channel. The flow rate of the mixture can be incremented or decremented by changing the set point of the master channel #1. From the Program Settings Display (See section e.3.10), press the Enter button under RATIO on the display, to set up the RATIO table. The following display will appear.

```
C H 3   R A T I O   M O D E :   D I S A B L E
N E X T   E N B L           D I S B L   E X I T
```

Ratio mode settings for third channel on the Multi-channel SDPROC

By default, Ratio Mode is disabled for each channel. In order to be able to enable Ratio Mode, the value of the ratio in % for a particular channel has to be more than 0%. It is recommended to begin Ratio settings from the master channel #1 (master channel has to be set to the highest value from the mixture). For example, if four gas mixtures are desired with ratios: Gas#1=30%, Gas#2= 25%, Gas#3=25% and Gas#4=20% the Gas#1 has to be set on channel#1 (master channel). In order to setup channel#1 from the above screen, press the Esc button under NEXT on the display until the following screen will appear.

```

C H 1   R A T I O   M O D E :   D I S A B L E
N E X T   E N B L       D I S B L       E X I T
  
```

Ratio mode settings for first channel on the Multi-channel SDPROC

Press one more time the Esc button under NEXT on the display, in order to go to the Ratio value settings screen. The following display will appear.

```

C H 1   R A T I O :       0 . 0 %   1 0 0 . 0 % !
N E X T           +           -           E X I T
  
```

Ratio value settings for first channel on the Multi-channel SDPROC

Pressing (+) or (-) will increment or decrement the Ratio Value settings per 0.1% F.S. respectively. The number in the upper right corner of the screen, represents the total value of the mixture (the sum of the ratio values for all available channels). It is important to have this number equal to 100% in the end of the ratio settings (otherwise the Ratio mode will not operate properly). When complete with Ratio value settings for the first channel, press the Esc button under NEXT on the display, to go to the ratio settings for the second channel. The following display will appear.

```

C H 2   R A T I O   M O D E :   D I S A B L E
N E X T   E N B L       D I S B L       E X I T
  
```

Ratio mode settings for second channel on the Multi-channel SDPROC

NOTE: The ratio mode for channel#2 is disabled because the ratio value is set to zero by default. Press one more time the Esc button under NEXT on the display, to go to the ratio settings for the second channel. The following display will appear.

```

C H 2   R A T I O :       0 . 0 %   3 5 . 0 % !
N E X T           +           -           E X I T
  
```

Ratio value settings for second channel on the Multi-channel SDPROC

NOTE: This assumes that the ratio value for the master channel#1 was set to 35%. Continue with ratio value settings for all required channels.

⚠ Make sure that the total value of the mixture is equal to 100% in the end of the ratio settings for all required channels.

When complete with ratio value settings for all required channels, go to the ratio mode settings screen for each required channel and change the ratio mode from DISABLED to ENABLED.

⚠ Make sure that the reference for set point is set to PROGRAM RATIO mode for all required channels in order for the Ratio program to be executed (see section e.3.7.1).

In order to change the flow rate for the mixture of gases use the Set Point screen for the master channel#1 (See section e.3.4). While adjusting the set point for the master channel in the Ratio mode, the SDPROC will automatically check the adjusted set point for slave channels in order to keep them within the range between 2.0 and 100% F.S. When complete with ratio settings, press the ENTER button under EXIT on the display, to go to the Main Display screen.

e.3.11 All Valves Control

It may on occasion be desirable to set all the channels in the flow system to the same mode of operation simultaneously. While in the Main Display press the ESC button on the front panel of the SDPROC. The following screen will then appear.

ALL VALVES CONTROL			
EXIT	CLOSE	OPEN	AUTO

All Valves Control Mode Display for Multi channel SDPROC

Choosing CLOSE, OPEN, or AUTO from this menu, will apply to all channels connected to the multi channel SDPROC. After making the selection, the Main Display returns. Select EXIT if no changes are desired. The following **Real-time Clock Settings** display will appear.

e.3.12 Real-time Clock Settings

```
1 4 : 5 3 : 0 8   T U E   0 9 / 0 2 / 2 0 0 3  
E X I T           +       -           S E T .
```

Real Time Clock Settings Display for SDPROC

Normally date and time for the Real-time Clock are set by the factory, unless the battery was replaced, or the CPU core was removed from the main board of the SDPROC. In order to change date and time settings press the ENTER button under SET on the display. This will activate the flashing cursor on the hours position. Pressing (+) or (-) will increment or decrement the time settings (hours). When complete with hours settings press again the ENTER button to move the flashing cursor to the minutes position. When complete with minutes settings press again the ENTER button to move the flashing cursor to the seconds position. When done with time settings press again the ENTER button to move the flashing cursor to the date position (month, date and year) respectively. When done with years settings press again the ENTER button to disable Real-time settings and update new time and date.

⚠ Proper settings of the Real-time Clock is essential for the Timer program to be executed correctly.

When complete with Real-time Clock settings, press the ENTER button under EXIT on the display, to go to the Main Display screen.

e.3.13 Status Check

While in the Main Display, press the UP button on the front panel of the SDPROC. The Set point Status in % F.S. for all channels will appear.

```
S e t # 1 = 1 0 0 . 0 %   # 2 =   5 0 . 0 %  
S e t # 3 =   7 5 . 0 %   # 4 =   2 5 . 0 %
```

Set point Status Display for Multi channel SDPROC

Pressing the UP button again will bring up the Set point Status in current engineering units for all channels.

```
S   5 . 0 0 0   S L P M   2 . 5 0 0   S L P M  
S   3 . 7 5 0   S L P M   1 . 2 5 0   S L P M
```

Pressing the UP button again will bring up the Valve Mode Status for all channels.

```
V a l v e   # 1 = A U T O   # 2 =   A U T O  
V a l v e   # 3 = A U T O   # 4 =   A U T O
```

Valve Mode Status Display for Multi channel SDPROC

Pressing the UP button again will bring up the Alarm Mode Status for all channels.

A L M # 1 = D I S A B L E	# 2 = D I S A B L E
A L M # 3 = D I S A B L E	# 4 = D I S A B L E

Alarm Mode Status Display for Multi channel SDPROC

Pressing the UP button again will bring up the Totalizer Mode Status for all channels.

T 1 = D I S A B L E	# 2 = D I S A B L E
T 3 = D I S A B L E	# 4 = D I S A B L E

Totalizer Mode Status Display for Multi channel SDPROC

Press UP one more time to return to the Main Display. **NOTE:** Pressing the Down button from any of the status screens will switch status display to one step back.

(f) MAINTENANCE

The SDPROC does not require any regular maintenance. Any repair of defective components or parts of the SDPROC should be referred to your distributor or Aalborg® (also see the TROUBLESHOOTING GUIDE section in this manual).

To replace AC inlet power fuses, turn the SDPROC power switch off. Remove the AC power line cord from the inlet connector at the rear panel of the SDPROC. Slide the fuse drawer open. Replace the defective fuse(s) with a 2A FF (very quick acting) fuse. Slide the fuse drawer back in. Reconnect the AC the power line cord. Continue SDPROC operation.

⚠ CAUTION: TO PROTECT SERVICING PERSONNEL IT IS MANDATORY THAT ANY INSTRUMENT BEING SERVICED IS COMPLETELY PURGED AND NEUTRALIZED OF TOXIC, BACTERIOLOGICALLY INFECTED, CORROSIVE OR RADIOACTIVE CONTENTS.

(g) ADC/DAC CALIBRATION PROCEDURES

The ADC/DAC calibration for your SDPROC was performed at the factory. It is not required to perform recalibration unless the firmware was reinitialized, or the main PC board was replaced.

📄 NOTE: Removal of the factory installed calibration seals and/or any adjustments made to the instrument, as described in this section, will void any calibration warranty applicable.

Turn the power off to the SDPROC. While the Esc and Enter buttons are pressed, turn the SDPROC on. Continue to press Esc and the Enter buttons until the calibration

```

*** Calibration mode ***
EXIT          A / D          D / A

```

Calibration Mode Display

Proceed with instructions outlined in sections g.1 and g.2.

g.1 Digital to Analog (D/A) Slope Calibration

Select the D/A calibration mode from the Calibration Menu. The following display will appear.

```

Set 5.00V 1st ch. output
EXIT      +      -      CAL

```

 **NOTE:** The digital to analog (D/A) slope has to be calibrated for each channel individually!

Using an accurate digital multimeter, measure the A/D output DC voltage between pins 9 (positive) and 10 (ground) of the Channel 1 15 pin “D” connector. Set the output DC voltage for exactly 5.000 VDC using the “+” and “-” controls (UP and DOWN buttons respectively, on the front panel of the SDPROC). When the “+” or “-” controls is pressed at least once, the following display will appear.

```

CHANNEL # 1 D / A VAL. : 4079
EXIT      +      -      CAL

```

The display should show the D/A value between 3900 and 4095. Save the D/A slope parameter by pressing CAL (ENTER button). For the one channel SDPROC the following display will confirm your setting.

```

D / A slope has been
stored, press any key.

```

Press any key to return to the Calibration Mode Display.

For Multi channel SDPROC's, the calibration software will prompt for the second channel.

```

Set 5.00V 2nd ch. output
EXIT      +      -      CAL

```

Using an accurate digital multimeter, measure the D/A output DC voltage between pins 9 (positive) and 10 (ground) of the Channel 2 15 pin “D” connector. Set the output DC voltage for exactly 5.000 VDC using the “+” and “-” controls (UP and DOWN buttons respectively, on front panel of SDPROC). When the “+” or “-” controls are pressed at least once, the following display will appear.

```
CHANNEL # 2 D / A VAL . : 4068
EXIT      +      -      CAL
```

The display should show the D/A value between 3900 and 4095. Save the D/A slope parameter by pressing the CAL (ENTER button). Proceed with D/A calibration for as many channels as required. When digital to analog (D/A) slope is calibrated for last available channel, the following display will appear.

```
D / A slope has been
stored, press any key.
```

g.2 Analog to Digital (A/D) Calibration

Select the A/D calibration mode from the Calibration Menu. The following display will appear.

```
Apply 5.000V to the all
input ch. & press a key.
```

Connect exactly 5.000 VDC to pin 3 for all available channels on the 15 pin “D” connectors and ground to pin 10.

 **NOTE:** Make sure the inputs from all available channels (pin 3 on the 15 pin “D” connector) are connected to a stable source of the voltage 5.000 Vdc (failure to do so, will result in incorrect SCALE calibration for channels which are not connected to 5.000 Vdc).

Press any key when done with 5.000 Vdc connections. The following display will appear.

```
SCALE # 1    193  # 2    186
EXIT  # 3    198  # 4    191 CAL
```

NOTE: The screen above assumes four channels SDPROC. The number of SCALE readings on the screen will correspond to the number of channels for the SDPROC being calibrated. The display should show the A/D scale values between 150 and 250. If any value is outside of those limits, the PC board is defective. Save the A/D scale parameters by pressing the CAL (ENTER button). The following display will appear.

```
Apply 0.00V to the all
input ch. & press a key.
```

Connect pin 3 for all available channels on the 15 pin “D” connectors to the ground (pin 10).

 **NOTE:** Make sure the inputs from all available channels (pin 3 on the 15 pin “D” connector) are connected to the common pin 10 (failure to do so, will cause incorrect OFFSET calibration for channels which are not connected to ground).

Press any key when done with 5.000 Vdc connections. The following display will appear.

```
OFFS. #1 3910 #2 3914  
EXIT #3 3921 #4 3912 CAL
```

The display should show the A/D offset values between 3850 and 4095. If any value is outside of those limits, the PC board is defective. Save the A/D offset parameters by pressing the CAL (ENTER button). The following display will appear.

```
New ADC par. have been  
stored, press any key.
```

Calibration of the SDPROC is complete. Press any key to return to the Calibration Mode Display, then press the EXIT button to return to the Main Display.

(h) RS-232 SOFTWARE INTERFACE COMMANDS

h.1 General

RS232 serial communication is supported via a standard 9 pin D-Connector on the back panel.

To use the serial interface:

1. Connect the SDPROC to a PC or other DTE type terminal via a standard serial cable (no null modem is required).
2. Set the communications port parameters on the terminal to 9600 baud, 8 data bits, 2 stop bits and no parity.
3. A commercially available terminal program or a custom software program can be used to control the SDPROC.

h.2 Commands Structure

The commands supported are listed in the table below. If the continuous data command is issued the output will appear as:

```
#1: XXX.X%I #2: XXX.X%E #3: XXX.X%I #4: XXX.X%E [CR] [LF]
```

This assumes that the data is from a four channel SDPROC with channels 1 and 3 set to utilize the internal reference and channels 2 and 4 set to utilize an external reference via the DB25 connector. The output from a two channel SDPROC unit with un-calibrated ADC will appear as follows:

```
#1: XXX.X%I *#2: X XX.X%I* [CR] [LF]
```

The protocol described below allows for communications with the unit using either a custom software program or a “dumb terminal.” All values are sent as printable ASCII characters. The command parameters are delimited by a space character and the command string is always terminated with a carriage return character, (line feeds are automatically stripped out by the SDPROC).

The structure of the command string:

Cmd Arg1 Arg2 Arg3 Arg4 [CR]

Where: Cmd The two or three characters command from the table below.

Arg1 to Arg4 The command arguments from the table below. Multiple arguments are delimited by a space character.

[CR] Carriage return character.

When a valid command is sent to the SDPROC the unit will respond as indicated in the table. If an invalid command is sent, the unit will respond with “[string] ERROR” where “string” refers to the characters that were received by the SDPROC (**NOTE:** the length of the string has to be at least two characters long).

Several examples of both valid and invalid commands follow:

- 1. Turn on the check sum: CS 1[CR]
 The unit will reply: CS 1 OK[CR] [LF]

- 2. To transmit data every 30 sec: CD 30[CR]
 The unit will reply: CD 30 OK[CR] [LF]
 Followed by: #1:X XX.X%I #2: XXX.X%I[CR][LF][Y Y]

(This will repeat every 30 sec and assumes a two channel SDPROC with error checking enabled. XXX.X is the flow reading in % FS; I is internal reference for set point; YY is the two character check sum).

- 3. Transmit Set Point to channel #2: SP 2 50.0[CR]
 The unit will reply: SP 2 50.0 OK[CR] [LF]

- 4. An example of an invalid command to a 2 channel SDPROC:
 SP 3 106.0[CR]
 The unit will reply: SP 3 106.0 ERROR:WRONG CHN#[CR][LF]

(The channel number greater than 2 and desired flow greater than 105.0 are both invalid).

h.3 ASCII Commands

No	Type	Description	Command	Argument 1	Argument 2	Argument 3	Argument 4	Return string
1	GENERAL CONTROL COMMANDS	Set Full Scale Flow in SLPM	FF	CHANNEL 1 char. [1-4]	VALUE float [0-99999.0]			FF CHANNEL VALUE K[CR][LF] Ex: FF 4 10.0 [CR][LF]
2		Set current Engineering Units INDEX: 0 - % F.S. 1 - SLPM 2 - SLPH 3 - SCCM 4 - SCCH 5 - SCFM 6 - SCFH 7 - SCMM 8 - SCMH 9 - LBPH 10 - LBPM 11 - GrPH 12 - GrPM	EU	CHANNEL 1 char. [1-4]	INDEX 1 char. [0-12]			EU CHANNEL UNITS OK[CR] [LF]Ex: EU 3 SLPM OK [CR][LF] NOTE: for engineering units 9-12 the value of the gas density has to be specified with DW command.
3		Set control REFERENCE INDEX: 0 - INTERNAL 1 - EXTERNAL 2 - BATCH 3 - TIMER 4 - RATIO***	RF	CHANNEL 1 char. [1-4]	INDEX 1 char. [0-4]			RF Ch In OK [CR][LF] Ex: RF 1 [CR][LF]
4		Set VALVE MODE MODE: 0 - CLOSE 1 - AUTO 2 - OPEN	VM	CHANNEL 1 char. [1-4]	MODE 1 char. [0-2]			VM Ch Md OK[CR][LF] Ex: VM 1 1 [CR][LF]
5		SET POINT in % F.S.	SP	CHANNEL 1 char. [1-4]	VALUE float [0-105.0]			SP Ch Val OK[CR][LF] Ex: SP 1 75.0 [CR][LF]
6		Set Gas Density in G/L	DW	CHANNEL 1 char. [1-4]	VALUE float [0-999.999]			DW CH Value OK[CR][LF] Ex: DW 1 1.293 OK[CR][LF]
7		Read Gas Density in G/L	DR	CHANNEL 1 char. [1-4]				DENSITY#CH: V g/L[CR][LF] Ex: DENSITY#4: 1.293 g/L [CR][LF]
8		Continuous Data control Will activate single data request with time interval equal to the SECONDS. If SECONDS = 0 continuous data output will be disabled.	CD	SECONDS [0- 32767] *0				CD SEC. OK [CR][LF]

No	Type	Description	Command	Argument 1	Argument 2	Argument 3	Argument 4	Return string
9	GENERAL CONTROL COMMANDS	Single Data Request Returns a string containing readings in %F.S. for all available channels.	SD	NON				String with current reading in %F.S for all channels. If channel not calibrated [*] will be added to the reading.
10		Turns ON/OFF the 16 bit check sum transmission of check sums with the data packet. MODE: 0 - OFF 1 - ON	CS	MODE char [0 - 1] *0				CS MODE OK[CR][LF] Ex: CS 0 OK[CR][LF]
11	TOTALIZER SETTINGS AND STATUS COMMANDS	Set TOTALIZER start FLOW in %F.S.	TS	CHANNEL 1 char. [1-4]	VALUE float [0-105.0]			TS CH VALUE OK[CR][LF] Ex: TS 2 5.0 OK[CR][LF]
12		Set TOTALIZER stop VOLUME in current volume based E.U.	TP	CHANNEL 1 char. [1-4]	VOLUME [0-999999.8]			TP CH VOLUME OK[CR][LF] Ex: TP 2 1000 OK[CR][LF]
13		Set TOTALIZER MODE	TM	CHANNEL 1 char. [1-4]	MODE [0-1] 0- DISABLE 1- ENABLE	ACTION [0-2] 0 - NON 1- BUZER 2 - VALVE CLOSE		TM CH MODE ACTION OK[CR][LF] Ex: TM 1 1 2 OK[CR][LF]
14		Reset TOTALIZER to ZERO	TZ	CHANNEL 1 char. [1-4]				TZ CH OK[CR][LF] Ex: TZ 2 OK[CR][LF]
15		Read TOTALIZER VOLUME Returns volume in current E.U.	TR	CHANNEL 1 char. [1-4]				TOT#CH: VOL EU[CR][LF] TOT#2: 1005.5 L[CR][LF]
16	TOTALIZER SETTINGS AND STATUS COMMANDS	TOTALIZER Status command Returns current settings for all available channels (mode, action, start flow)	SCT	NON				SCT M M A A SF SF[CR][LF] Ex: SCT 1 1 2 2 2.5 5.0[CR][LF] (for two channels SDPROC)
17		Second TOTALIZER Status command. Returns current STOP VOLUME settings for all available channels.	STS	NON				STS VOL VOL[CR][LF] Ex: STS 1000.0 15000.0[CR][LF] (for two channels SDPROC)
18	ALARM SETTINGS AND STATUS COMMANDS	Set ALARM MODE	AM	CHANNEL 1 char. [1-4]	MODE [0-1] 0- DISABLE 1- ENABLE	ACTION [0-2] 0 - NON 1- BUZER 2 - VALVE CLOSE	DELAY In seconds	[0 - 65535] AM CH MODE ACTION OK[CR][LF] Ex: AM 1 1 2 0 OK[CR][LF]
19		Set ALARM LOW flow margin in %F.S.	AL	CHANNEL 1 char. [1-4]	VALUE float [0-105.0]			AL CH VALUE OK[CR][LF] Ex: AL 2 5.0 OK[CR][LF]

No	Type	Description	Command	Argument 1	Argument 2	Argument 3	Argument 4	Return string
20	ALARM SETTINGS AND STATUS COMMANDS	Set ALARM HIGH flow margin in %F.S.	AH	CHANNEL 1 char. [1-4]	VALUE float [0-105.0]			AH CH VALUE OK[CR][LF] Ex: AH 2 5.0 OK[CR][LF]
21		Read ALARM STATUS Returns: 0 - NO ALARM 1 - HIGH ALARM 2 - LOW ALARM	AS	NON				AS ST ST[CR] [LF] Ex: AS 0 2[CR][LF] (example above for two channels SDPROC)
22		ALARM Status command. Returns current settings for corresponding channel (mode, action, high and low margins, action delay)	SCA	CHANNEL 1 char. [1-4]				A Ch1: M A HM LM D[CR][LF] Ex: A Ch1: 1 2 2.5 5.0 0 [CR][LF]
23	RELAYS ASSIGNMENT AND STATUS	RELAYS ASSIGNMENT	RA	CHANNEL 1 char. [1-4]	RELAY# [0-1] 0 -Relay #1 1 -Relay #2	ACTION [0-3] 0- No action 1- Alarm High 2- Alarm Low 3- Totalizer		RA CH RL# ACTION OK[CR][LF] Ex: RA 2 0 3 OK[CR][LF]
24		Read RELAYS ASSIGNMENT STATUS Returns current assignments of the relays (two for each channel) for all available channels.	SRS	NON				SRS A A A A[CR][LF] Ex: SRS 0 0 13[CR][LF] (for two channels SDPROC)
25	BATCH SETTINGS	Set BATCH properties: -mode [0-1] -loop OFF/ON [0-1] -number of the step to execute [1-16].	BM	CHANNEL 1 char. [1-4]	MODE [0-1] 0- DISABLE 1- ENABLE	LOOP [0-1] 0- DISABLE 1- ENABLE	# STEPS [1-16]	BM CH MD LP ST OK[CR][LF] Ex: BM 2 0 0 10 OK[CR][LF]
26		Set BATCH time and set point values for particular step number [1-16].	BS	CHANNEL 1 char. [1-4]	STEP NUMBER [1-16]	SET POINT float [0-105.0]	TIME In seconds [0 - 99999]	BS CH ST SP TM OK[CR][LF] Ex: BS 1 1 100.0 60 OK[CR][LF]
27		Save BATCH array to the SDPROC.	BW	NON				BW OK[CR][LF]
28	TIMER SETTINGS	TIMER SETTINGS Setup TIMER PROGRAM Total available up to 96 steps. For each active step set point and time string has to be entered. Time string has to be 16 characters long.	PS	CHANNEL 1 char. [1-4]	STEP NUMBER [0-96]	SET POINT float [0-105.0]	TIME formatted string: [hh:mm,mm /dd/yyyy] Total 16 ch.	PS CH ST SP TIME K[CR][LF] Ex: PS 1 4 50.0 20:30,10/24/2002 OK[CR][LF]29 Save TIMER array to the SDPROC. PW NON PW OK[CR][LF]
29		Save TIMER array to the SDPROC.	PW	NON				PW OK [CR] [LF]

No	Type	Description	Command	Argument 1	Argument 2	Argument 3	Argument 4	Return string
30	GENERAL STATUS COMMANDS	General status command #1 Returns: Instrument model, TCP/IP flag, Full scale flow in SLPM, Current E.U For all available channels.	SCF	NON				SCF MODEL T XXX.X XXX.X U U OK[CR][LF] Ex: SCF SDPROC2 0 5.000 1.000 1 1 OK[CR][LF] (for 2 channels instrument)
31		General status command #2 Returns: Reference, Valve mode, Set Point For all available channels.	SCS	NON				SCS R R V V XXX.X XXX.X OK[CR][LF] Ex: SCS 0 0 1 1 25. 0 50.0 K[CR][LF] (for 2 channels instrument)
32	TPC/IP CONFIGURATION AND STATUS COMMANDS	Set Instrument IP ADDRESS** IP address string must have decimal notation (example: 198.192.1.104) maximum 15 characters are allowed.	IPC	IP ADDRESS String: XXX.XXX.XX X.XXX				IPC XXX.XXX.XXX. XXX OK[CR][LF] Ex: IPC 2.168.1. 19 OK[CR][LF]
33		Read current IP ADDRESS**	IPS	NON				Device IP Address: 192.168.1.19 [CR][LF]
34		Set Instrument Subnet Mask** Subnet mask string must have decimal notation (example: 255.255.255.0) maximum 15 characters are allowed.	SMC	Subnet Mask String: XXX.XXX.XX X.XXX				SMC .XXX.XXX. XXX OK[CR][LF] Ex: SMC 255.255.255.0 OK[CR][LF]
35		Read current Subnet Mask**	SMS	NON				Device Subnet Mask: 55.255. 255.0 [CR][LF]
36		Set Instrument Default Gateway ** Default Gateway string must have decimal notation (example: 198.192.1.1) maximum 15 characters are allowed.	DGC	Device Default Gateway String: XXX.XXX.XX X.XXX				DGC XXX.XXX.XXX.XXX OK[CR][LF] Ex: DGC 192.168. 1.1 OK[CR][LF]
37		Read current Default Gateway IP address**	DGS	NON				Device Default Gateway: 192.168.1.11 [CR][LF]
38		Set Instrument Name Server** Name Server string must have decimal notation (example: 64.85.127.15) maximum 15 characters are allowed.	NSC	Device Name Server String #1: XXX.XXX.XX X.XXX	Device Name Server String #2: XXX.XXX.X XX.XXX			NSC XXX.XXX.XXX.XXX XXX.XXX.XXX.XXX OK[CR][LF] NSC 64.85.127. 15 64.85.127.55 OK[CR][LF]

No	Type	Description	Command	Argument 1	Argument 2	Argument 3	Argument 4	Return string
39	TCP/IP CONFIGURATION AND STATUS COMMANDS	Read current Name Server IP address**	NSS	NON				Device Name Server: .85.127. 15 64.85.127.55 [CR][LF]
40		Set User Name and User Password**	UAC	User NAME (max. 10 characters)	User Password (max. 10 characters)			UAC user password OK[CR][LF]
41		Read current User Name and User Password**	UAS	NON				User Name: user[CR][LF]User Password: password[CR][LF]
42		Set Domain Name and Host Name**	DHC	Domain Name (max. 25 characters)	Host Name (max. 25 characters)			DHC Domain Host OK[CR][LF]
43		Read current settings for Domain Name and Host Name**	DHS					Domain Name: aalborg.com[CR] [LF] Host Name: sdproc[CR][LF]
44		Set the DHCP flag (will take affect on next power up)** 0 - DHCP disabled 1 - DHCP enabled	DHP	MODE char [0 - 1]*0				DHP MODE OK[CR][LF]
45	Set the ETHERNET mode (will take affect on next power up)** 0 - HTML server 1 - TELNET console	TLN	MODE char [0 - 1]*0				TLN MODE OK RESET POWER![CR][LF] Ex: TLN 0 OK RESET POWER! [CR][LF]	

* Power on default setting

** Only valid for TCP/IP compatible hardware. If changed, will take affect on next power up.

*** Only applicable for Multi-channel SDPROC.

(i) Network Communication Interface (optional)

i.1 10Base-T RJ-45 Pinout

The optional 10Base-T Ethernet network (RJ-45) system is used in the SDPROC for network connectivity. The 10 Mbps twisted-pair Ethernet system operates over two pairs of wires. One pair is used for receiving data and the other pair is used for transmitting data. Total four pins of the eight-pin connector is used.

PIN	NAME	DESCRIPTION
1	+Tx	+ Transmit Data
2	-Tx	- Transmit Data
3	+Rx	+ Receive Data
4	N/C	Not Connected
5	N/C	Not Connected
6	-Rx	- Receive Data
7	N/C	Not Connected
8	N/C	Not Connected

Figure i-1, RJ-45 Pinout.

 **NOTE:** When connecting the SDPROC directly to the computer, the transmit data pins of the computer should be wired to the receive data pins of the SDPROC, and vice versa. In order to implement this connection the crossover cable has to be used. Use straight through cable for connecting the SDPROC to an Ethernet hub.

i.2 Network Protocols

The SDPROC can be connected to the network using standard TCP/IP protocols. It also supports ARP, HTTP (WEB Server), DHCP, DNS, and Telnet protocols.

i.2.1 DHCP

DHCP, Dynamic Host Configuration Protocol enables an individual device to extract their IP configuration from the DHCP server. If DHCP is enabled on the SDPROC, as soon as the SDPROC is powered up and connected to the network, there is an exchange of information between the DHCP server and the SDPROC. During this process the IP address, the Gateway address, and Subnet Mask will be assigned to the SDPROC. If fixed or static IP address is desired, the DHCP must be disabled (see TCP/IP Configuration and Status Commands, section h.3). The SDPROC is shipped with DHCP disabled (factory default). The DHCP can be enabled through the serial interface command DHP with argument 1. **NOTE:** New DHCP settings will take affect only on the next power up (see TCP/IP Configuration and Status Commands, section h.3).

i.2.2 DNS

DNS, Domain Name System enables individual computers and devices to be recognized over the network base on specific name instead of an IP address. For example, instead of having to use <http://192.168.1.19> (which is device IP address), we can use only <http://sdproc> or any eight characters name stored as the Host Name in the SDPROC. By default each device shipped with Host Name: sdproc.

 **NOTE:** It is very important to communicate with the network administrator in order to assign correct settings for the IP address and DHCP mode on the SDPROC. The SDPROC is shipped with a default static IP address of **192.168.1.19** and Subnet Mask of **255.255.255.0**

i.2.3 IP Address

Every active device connected to the TCP/IP network must have a unique IP address. The IP address is divided into two portions, the network ID and the host ID. The SDPROC is shipped with the default IP address set to **192.168.1.19** and Subnet Mask of **255.255.255.0**. If you are going to use a Web browser or Telnet program to access the SDPROC using its default IP address, make sure that the PC from which you are establishing the connection has an IP address that is in the same range as the SDPROC's IP address (192.168.1.X, where X may be any number from 1 to 254).

 **NOTE:** Make sure your PC's Subnet Mask is 255.255.255.0

If the factory default address is already in use on your network, use the serial interface command IPC (see section h.3) in order to modify the IP address.

i.3 Configuration

The SDPROC with TCP/IP interface can be used and configured in two ways, depending on user's preferences and network setup. It can be used in Telnet simulation mode where it emulates serial communication operation and accepts all serial software interface commands (see section h.3), or directly from a Web browser, like Internet Explorer or Netscape.

 **NOTE:** The SDPROC is shipped with default configuration for HTML Web server. In order to change configuration to Telnet console use the serial interface command TLN with argument 1 (see section h.3 for details). The new mode of operation will take affect on the next power up.

When all required configurations are made, connect the SDPROC to the network and power it up. Use your PC that is connected over the same network and from the MS-DOS Prompt window type "ping 192.168.1.19" (use proper IP address if the device was reconfigured). This proves that the connection is proper and you can access SDPROC using the Web browser or Telnet.

```
Microsoft Windows [Version 5.00.2195]
(C) Copyright 1985-2000 Microsoft Corp.

C:\>ping 192.168.1.19

Pinging 192.168.1.19 with 32 bytes of data:
Reply from 192.168.1.19: bytes=32 time=90ms TTL=64
Reply from 192.168.1.19: bytes=32 time<10ms TTL=64
Reply from 192.168.1.19: bytes=32 time<10ms TTL=64
Reply from 192.168.1.19: bytes=32 time=40ms TTL=64

Ping statistics for 192.168.1.19:
    Packets: Sent = 4, Received = 4, Lost = 0 (0% loss),
    Approximate round trip times in milli-seconds:
        Minimum = 0ms, Maximum = 90ms, Average = 32ms

C:\>
```

Figure i-2 Pinging SDPROC MS-DOS Prompt

i.4 Operation Using the SDPROC Web Page

- a) Start your Web browser.
- b) From the browser type <http://192.168.1.19>
(if IP address was changed use new IP address).
- c) The Home Page, shown below, will be displayed.



Figure i-3 Network Password Page

- d) Enter User Name and Password and click OK.

NOTE: The SDPROC is shipped with default User Name: “user” and Password: “password”. For network security purposes you can change User Name and Password using the serial interface command UAC (see section h.3 for details). In order to use serial interface commands make sure that the serial cable is

Once you are done with the user Name and Password, the Home Page, shown below, will be displayed.

Figure i-4 Using SDPROC with Telnet Console

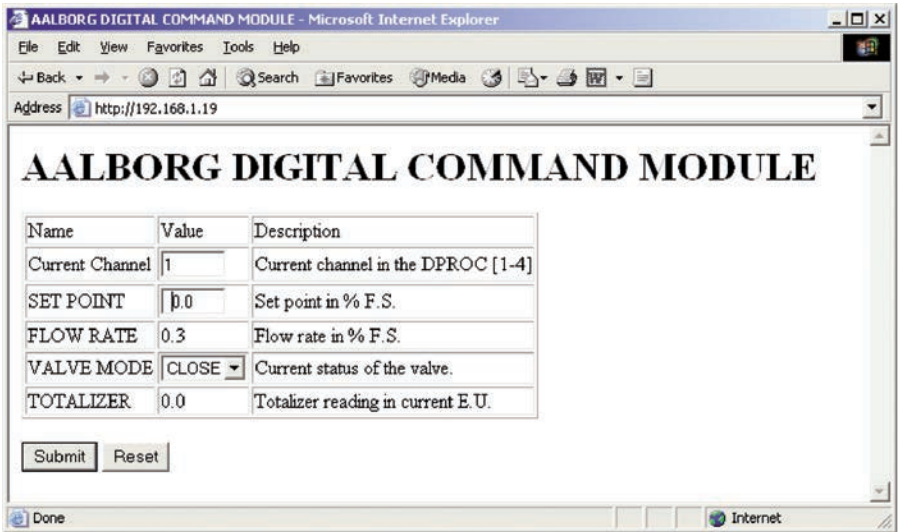

Figure i.4 SDPROC control Page

You can type the number of the channel you want to monitor or control. You can also enter the desired value of the set point. From the drop-down window you can select the valve control mode for the mass flow controller. When you are done with setting, click the [Submit] button in order to send the new configuration mode and set point to the SDPROC. The page will be updated with new values of the Flow Rate and the Totalizer readings.

i.5 Operation Using the SDPROC Telnet Console

Telnet stands for Telecommunication Network; it is a protocol that provides a way for users to connect to computers or servers on a network. The Windows Operating System includes the Telnet program. Use your PC that is connected over the same network and from the MS-DOS Prompt window type “telnet 192.168.1.19” (use the proper IP address if the device was reconfigured). Once in the Telnet window you can type any command from the software interface commands set (see section h.2). Examples of the SDPROC response in the Telnet session are provided below.

NOTE: In order to close Telnet session from Windows MS-DOS prompt, press the [Ctrl] button and type “].”

```

Command Prompt - Telnet 192.168.1.19
SCT 0 0 0 0 0 0 0 2.0 2.0 2.0 2.0
STS 100000.0 100000.0 100000.0 100000.0
DENSITY#1: 1.293000 g/L
#1= 0.3%I #2= 0.4%I #3= 0.2%I #4= 0.2%I
#1= 0.3%I #2= 0.4%I #3= 0.2%I #4= 0.2%I
#1= 0.3%I #2= 0.4%I #3= 0.2%I #4= 0.2%I
TOT#1: 0.0 L
SCT 0 0 0 0 0 0 0 2.0 2.0 2.0 2.0
STS 100000.0 100000.0 100000.0 100000.0
AS 0 0 0 0
SRS 0 0 0 0 0 0 0
Device IP Address: 192.168.1.19
Device Subnet Mask: 255.255.255.0
Device Default Gateway: 192.168.1.1
Device Name Server: 64.80.255.250

```

(J) TROUBLESHOOTING

J.1 Common Conditions

Your SDPROC Command Module was thoroughly checked at numerous quality control points during and after manufacturing and assembly operations. It was calibrated in accordance to your desired conditions and options.

It was carefully packed to prevent damage during shipment. Should you feel that the instrument is not functioning properly please check for the following common conditions first:

Are all cables connected correctly?

Is the power supply correctly selected according to requirements? When several meters are used a power supply with appropriate current rating should be selected.

Were the connector pinouts matched properly? When interchanging with other manufacturers' equipment, cables and connectors must be carefully wired for correct pin configurations.

J.2 Trouble Shooting Guide

INDICATION	LIKELY REASON	REMEDY
Lack of reading or output	Power supply off	Check connection of power supply
	Connector off	Check all cables for proper connection to the SDPROC and the mass flow transducer
	Transducer problem	Refer to the mass flow transducer manual
	Fuse blown	Disconnect power cord from AC supply; see section f for fuse replacement REMOVE CAUSE OF SHORT CIRCUIT!
In the Main Display, the flow reading is terminated with the asterisk character [*]	Not calibrated ADC	Perform ADC calibration procedure (see section g.2)
In the Set Point status screen, the set point value is terminated with the asterisk character [*]	Not calibrated DAC	Perform DAC calibration procedure (see section g.1)
In ALL VALVES CONTROL when pressing CLOSE or OPEN button the SDPROC resets itself.	Incorrect cable or configuration is used on one or more channels for Valve override control (short circuit).	Try to locate faulty channel by connecting devices to the SDPROC one by one. Once faulty device is located check the 15 pin D-connector pin configuration for valve override control (pins 8 and 12). NOTE: Connect and disconnect any interface cable only when the SDPROC is powered off.
Mass flow controller does not respond to set point adjustment	15-pin interface cable is incorrect type or not connected to the correct channel of the SDPROC	Check if correct type of the interface cable is used. Check if the interface cable is connected to the corresponding channel of the SDPROC.
	Reference for Set Point is set to EXTERNAL	Check the Reference mode for the corresponding channel and if required change it to INTERNAL.
	The Valve control mode is set to CLOSE	Check the Valve control mode for the corresponding channel and if required change it to AUTO.
	No inlet pressure for the mass flow controller.	Apply required inlet pressure to the mass flow controller.

For best results it is recommended that the instruments are returned to the factory for servicing. See section a.3 for return procedures.

J.3 Technical Assistance

Aalborg® Instruments will provide technical assistance over the phone or e-mail to qualified repair personnel. Please call our Technical Assistance at 845-770-3051. Please have your Serial Number and Model Number ready when you call.

The e-mail address for technical assistance is: support@ aalborg.com.

APPENDIX 1

COMPONENTS DIAGRAM

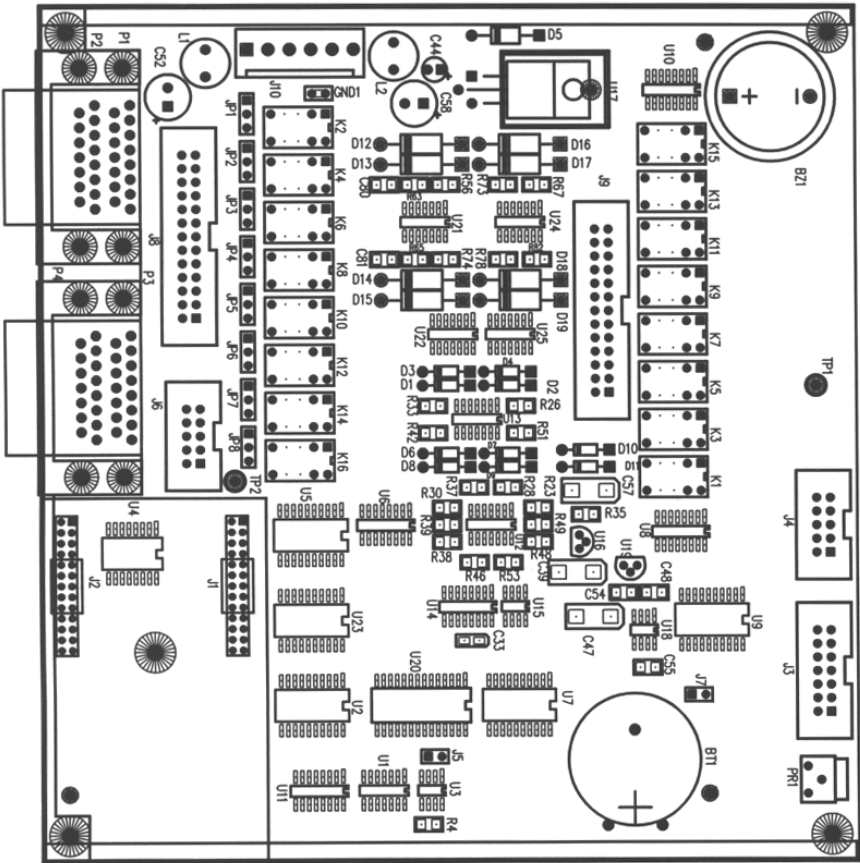

SDPROC MAIN PC BOARD

APPENDIX 2

DIMENSIONAL DRAWING

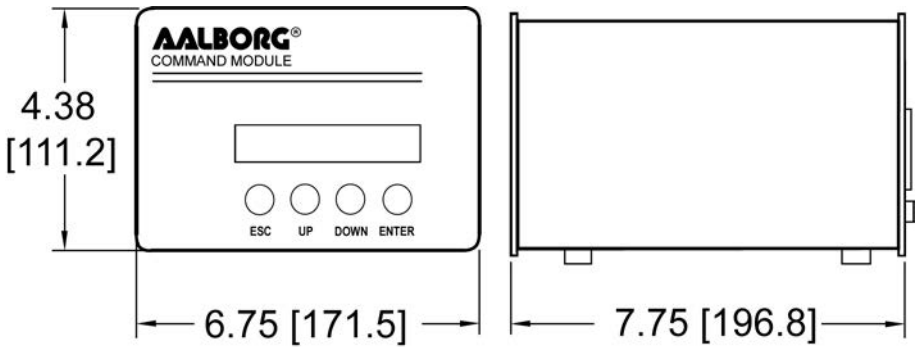

SDPROC COMMAND MODULE

NOTE: Aalborg® reserves the right to change designs and dimensions at its sole discretion at any time without notice. For certified dimensions please contact Aalborg®.

APPENDIX 3

WARRANTY

Aalborg® Mass Flow Systems are warranted against parts and workmanship for a period of one year from the date of purchase. Calibrations are warranted for up to six months after date of purchase, provided calibration seals have not been tampered with. It is assumed that equipment selected by the customer is constructed of materials compatible with gases used. Proper selection is the responsibility of the customer. It is understood that gases under pressure present inherent hazards to the user and to equipment, and it is deemed the responsibility of the customer that only operators with basic knowledge of the equipment and its limitations are permitted to control and operate the equipment covered by this warranty. Anything to the contrary will automatically void the liability of Aalborg® and the provisions of this warranty. Defective products will be repaired or replaced solely at the discretion of Aalborg at no charge. Shipping charges are borne by the customer. This warranty is void if the equipment is damaged by accident or misuse, or has been repaired or modified by anyone other than Aalborg or factory authorized service facility. This warranty defines the obligation of Aalborg® and no other warranties expressed or implied are recognized.

NOTE: Follow Return Procedures In Section a.3.